

Instrumentation Products

Needle Type Globe Valves and Accessories



Introduction

Introduction

The AS-Schneider Group with its headquarters in Germany is one of the World's Leading Manufacturers of Instrumentation Valves and Manifolds. AS-Schneider offers a large variety of Needle Type Globe Valves for General and Severe Service applications for liquids, gases and steam but also Accessories needed for the instrumentation installations globally.

Selection can be made from a comprehensive range of bodies with a variety of connections and material options, optimising installation and access opportunities. Many of the valves shown in this catalogue are available from stock or within a short period of time. The dimensions shown in this catalogue apply to standard types. If you need the dimensions for your individual type please contact the factory.

Continuous product development may from time to time necessitate changes in the details contained in this catalogue. AS-Schneider reserves the right to make such changes at their discretion and without prior notice.

All dimensions shown in this catalogue are approximate and subject to change.

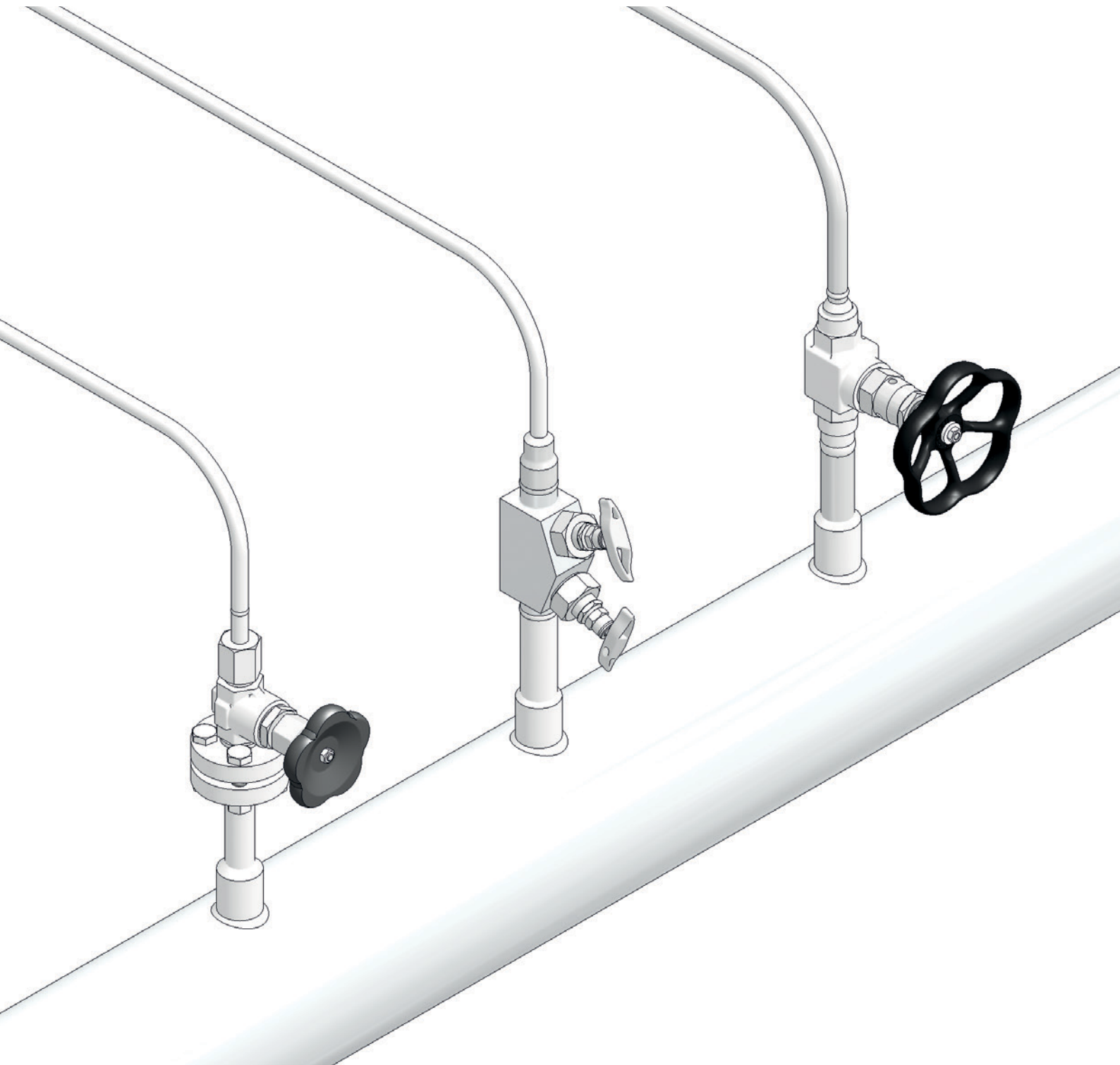

Introduction	page 2
Contents	page 3
Needle Type Globe Valves Overview	page 4-5
General Features and Connections	page 6-8
Integral Bonnet Needle Valves Type S338	page 9-10
Screwed Bonnet Needle Valves Type N334	page 11
Screwed Bonnet Needle Valves Type S350, S351	page 12-14
Angle Needle Valves Type S360	page 15
Y-Pattern Needle Valves Type S371	page 16
Screwed Bonnet Needle Valves Type S340, S381	page 17-18
Union Bonnet Needle Valves Type A1, B1	page 19-20
Bolted Bonnet Needle Valves Type A2	page 21
Welded Bonnet Needle Valves Type A4	page 22
Ordering Information for Needle Valves Type A1, B1, A2, A4	page 23
Condensate Pots, Weld Fittings and Threaded Pipe Ends	page 24-27

Needle Type Globe Valves Overview

Type S338

Integral Bonnet Needle Valves DN 6 / Bore Size 6 mm

- Forged Body
- Integral Bonnet
- Integral Valve Seat
- Internal Stem Thread

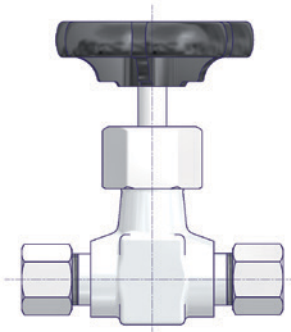

Type N334

Needle Valves DN 5 / Bore Size 5 mm

- Barstock Body
- Screwed Bonnet
- Integral Valve Seat
- Internal Stem Thread
- O-Ring Stem Seal
→ DVGW approved

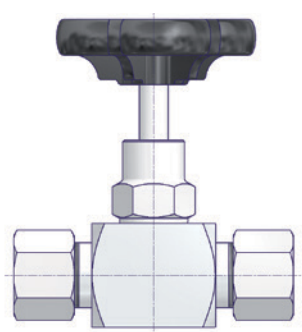

Type H

E Series Needle Valves DN 5 / Bore Size 5 mm

- Barstock Body
- Screwed Bonnet
- Integral Valve Seat
- External Stem Thread

Detailed information see Catalogue AS-2601 – E Series Valves and Manifolds - Hand Valves.

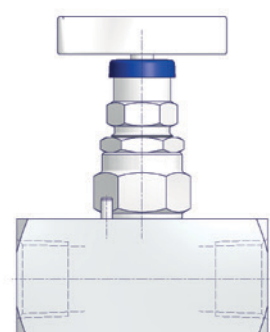

Type S350 / S351

Needle Valves DN 8 / Bore Size 8 mm

- Forged Body
- Screwed Bonnet
- Replaceable Valve Seat
- Stem Thread
 - S350 with Internal Stem Thread
 - S351 with External Stem Thread
 - F350 Bellows Sealed Option

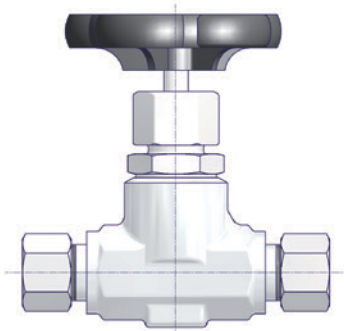

Type S360

Angle Needle Valves DN 8 / Bore Size 8 mm

- Forged Body
- Screwed Bonnet
- Integral Valve Seat
- Internal Stem Thread

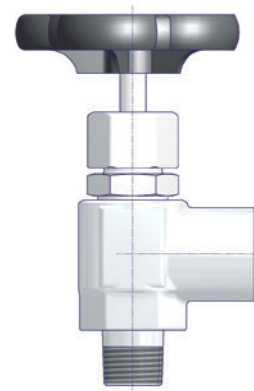

Type S371

Y-Pattern Needle Valves DN 8 / Bore Size 8 mm

- Forged Body
- Screwed Bonnet
- Integral Valve Seat
- External Stem Thread

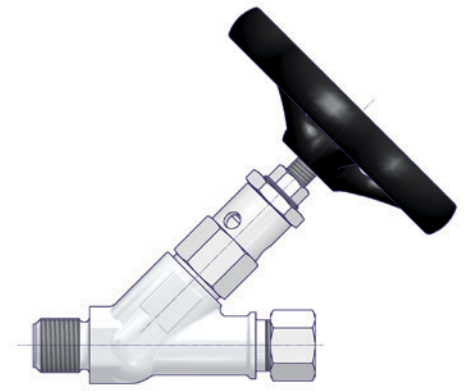

Straight Pattern

Angle Pattern

Y-Pattern (Oblique Pattern)

Valve Patterns

Needle Type Globe Valves Overview

Type S340 / S381

Primary Isolation Valves
DN 8 / Bore Size 8 mm

- Forged Body
- Screwed Bonnet
- Replaceable Valve Seat
- External Stem Thread

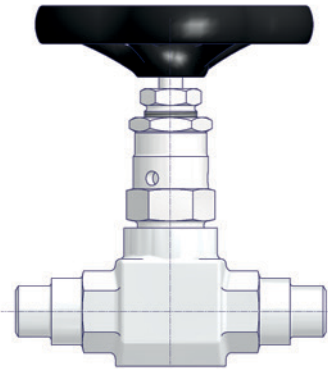

Type A1 / B1

Union Bonnet Needle Valves
Type A1: DN 11 / Bore Size = 11 mm
Type B1: DN 8 / Bore Size = 8 mm

- Barstock Body
- Union Bonnet Design
- Integral Valve Seat
- External Stem Thread

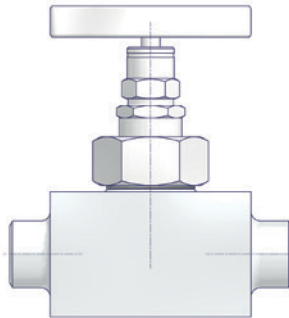

Type A1

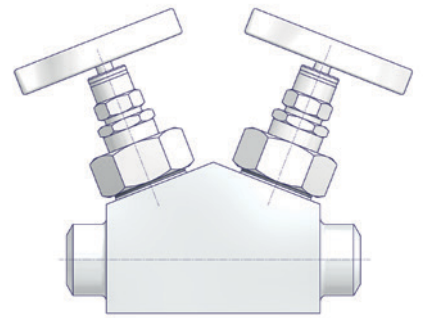

Type B1

Type A2

Bolted Bonnet Needle Valves
DN 20 / Bore Size 20 mm

- Barstock Body
- Bolted Bonnet Design
- Integral Valve Seat
- External Stem Thread

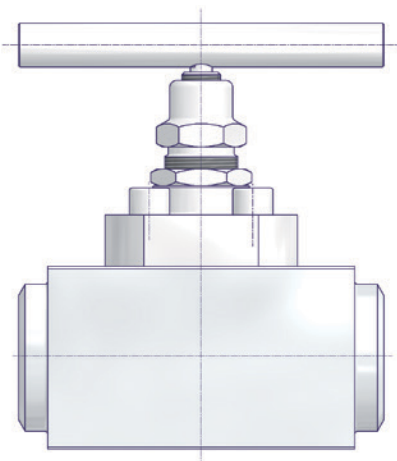

Type A4

Primary Isolation Valves
DN 10 / Bore Size 10 mm

- Barstock Body
- Welded Bonnet (extended)
- Integral Valve Seat

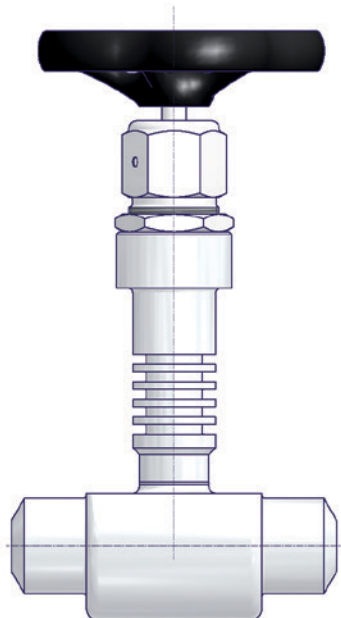

General Features

Body Material Options

Material Group	AS Material Designation	Material No.	Short Name	Equivalent UNS-No.	Material Grade acc. to ASTM	S338	N334	H*4	S350 / S351	S340 / S381	A1	B1	A2	A4
Heat Resistant Unalloyed Steel	Carbon Steel	1.0460	P250GH			S								
	LF 2				LF2		S	S						
	1.0460 / A105N*1					O			S	S				
Austenitic Stainless Steel		1.4571	X6CrNiMoTi17-12-2	S 31635	316Ti	S		O	S	S				
	316 Quadruple Certified*2	1.4401	X5CrNiMo17-12-2	S31600	316		S	S				S	S	
		1.4404	X2CrNiMo17-12-2	S 31603	316L									
		1.4919	X6CrNiMo17-12-2	S31609	316H						S			
Austenitic-Ferritic Stainless Steel	6 Mo	1.4547	X1CrNiMoCuN20-18-7	S 31254				S						
	Duplex	1.4462	X2CrNiMoN22-5-3	S 31803	F51			S				O		
		Superduplex	1.4410	X2CrNiMoN25-7-4	S 32750	F53			S				O	
	1.4501		X2CrNiMoCuWN25-7-4	S 32760	F55			S				O		
Heat Resistant Steel		1.5415	16Mo3							S		S	O	
		1.7335	13CrMo 4-5		F12					S*3		S		
		1.7383	10CrMo 9-10		F22					S*3		S	O	
		1.4901	X10 CrWMoVNb 9-2		F92					O				S
		1.4903	X10 CrMoVNb 9-1		F91					O	S	S	S	O
		1.4981	X8 CrNiMoNb 16 16											
Nickel Based Alloys	Alloy 400	2.4360	NiCu30Fe	N 04400				S				O		
	Alloy C-276	2.4819	NiMo 16 Cr 15 W	N 10276				S				O		
	Alloy 625	2.4856	NiCr22Mo9Nb	N 06625				S				O		
Titanium	Titanium Grade 2	3.7035	Ti-II	R 50400				S						

*1 Dual Certified

*2 Quadruple Certified means 316 / 316L / 1.4401 / 1.4404

*3 Dual Certified EN/ASTM

*4 See Catalogue AS-2601 - E Series Valves and Manifolds - Hand Valves

S = Standard | O = Optional

Standard Features

Packing:

PTFE and Graphite Packings are available for all valve types except the N334 Needle Valve which has an O-Ring stem seal.

Surface Treatment:

Carbon Steel Valves are phosphatized by default.

Pressure Test:

A shell test and a seat test are performed at 1.5 times the maximum working pressure acc. to EN 12266-1 - P10, P11 and P12 respectively MSS-SP61 at every standard AS-Schneider Needle Type Globe Valve.

Certification:

Inspection certificate 3.1 acc. to EN 10 204 for valve body material and pressure test available on request. The heat resisting materials (see table on Page 6) are available by default with inspection certificate 3.2!



Packing adjustment may be required during the service life of the valves.



Valves that have not been cycled for a period of time may have a higher initial actuation torque.

Valve Head Unit Options

Internal Stem Thread

Internal Stem Thread means Threads are in contact with process media.

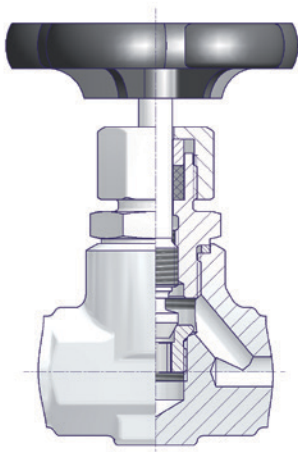

Stem Features

- Stem with cold rolled threads
- Back seat (except Integral Bonnet Needle Valve)
- Non-rotating needle tip or alternatively non-rotating needle

Valve Seat (Metal to Metal)

- Integral Valve Seat or Replaceable Valve Seat

Optional Features

Fugitive Emission Applications:

For Fugitive Emission Applications AS-Schneider is providing bellows sealed valves with safety packing. Choice of Pressure class PN 100 or PN 250 - Suffix P5 or P6.

The bellows are submitted to a 100% Helium leak test. Leak rate: 10^{-8} mbar l/s.

Optional available are TA-Luft and ISO 15848 solutions. For more details please contact the factory.

AS-Schneider offers 2 BAM tested options cleaned and lubricated for Oxygen Service:

PTFE Packing – Max. PN 420 (6,000 psi) - Suffix F5
 Pressure-Temperature Rating: Max. 420 bar @ 60°C
 Max. 200°C @ 90 bar

Graphite Packing – Max. PN 250 (3,625 psi) - Suffix F4
 Pressure-Temperature Rating: Max. 250 bar @ 60°C
 Max. 200°C @ 230 bar

Not every Valve type is available for Oxygen Service.

If you don't find your options in this catalogue, please contact the factory.

External Stem Thread

External Stem Thread means Packing below Stem Threads. Stem Threads are protected from process media (non-wetted), helps to prevent stems from galling.

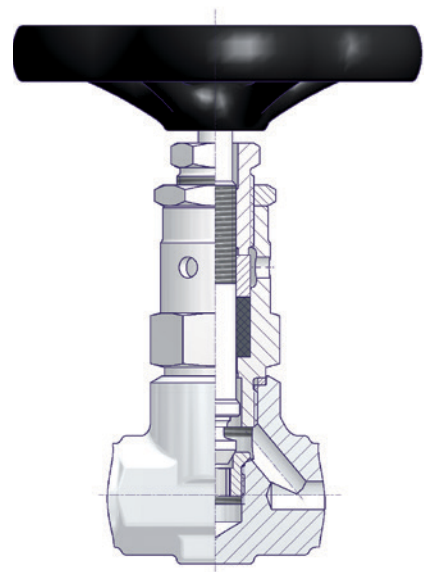

Connections

AS-Schneider is manufacturing a lot of different connections and connection combinations. In this catalogue we are showing the most popular types. On this page you will find the standard connections in detail.

Tube Fittings

Single Ferrule Tube Fittings
acc. to EN ISO 8434-1 Size S

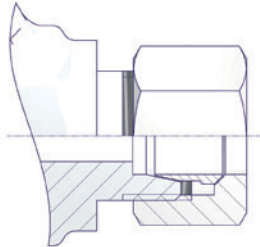

Twin Ferrule Tube Fittings

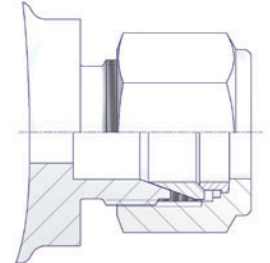

Tapered Pipe Threads

NPT Male Threads
acc. to ASME B 1.20.1

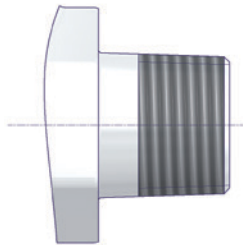

NPT Female Threads
acc. to ASME B 1.20.1



Parallel Pipe Threads

BSP Parallel Male Threads
acc. to DIN 19207 (G1/2)
acc. to DIN 3852

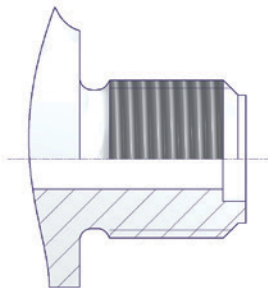

BSP Parallel Female Threads
acc. to ISO 228 (e.g. G 1/2)
acc. to DIN 3852-2 Form Z

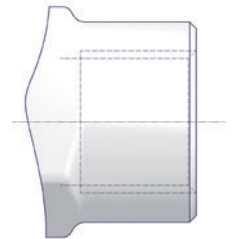

Weld Ends

Butt Weld Ends
for Pipes and Tubes
acc. to ASME B16.9 and
EN 12627

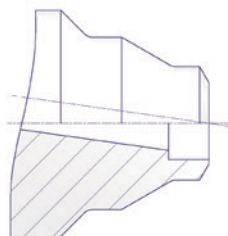

Socket Weld Ends
for Pipes and Tubes
acc. to ASME B16.11 and
EN 12760

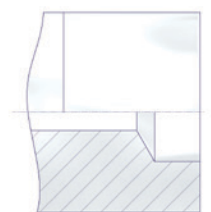

Combination of Pipe Butt
Weld End x Tube Socket
Weld End

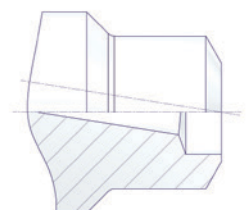

Integral Bonnet Needle Valves

Features

- Forged Body - DN 6 / Bore Size 6 mm
- Integral Bonnet
- Integral Valve Seat
- Internal Stem Thread
- Stem with cold rolled surface and non-rotating needle tip
- Standard-Packing PTFE (max. 232°C)
- Optional Graphite Packing (max. 300°C)

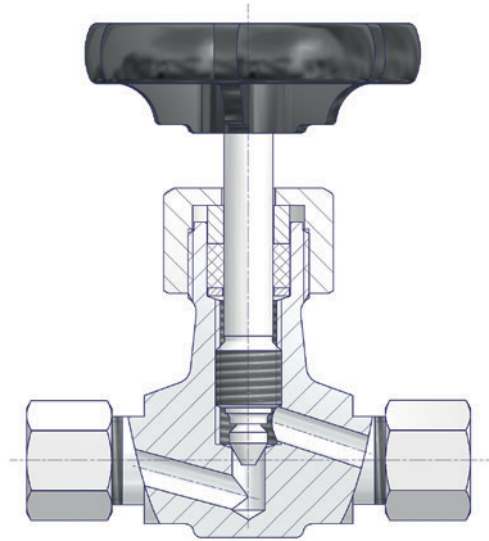

Components	Carbon Steel	Stainless Steel
	Material / Material No.	
Body	1.0460	1.4571
Valve Stem	1.4104	
Needle Tip	1.4122	
Packing	PTFE (Optional Graphite)	
Union Nut	Unalloyed Steel	1.4571
Tube Fitting		
Handwheel	Plastic	

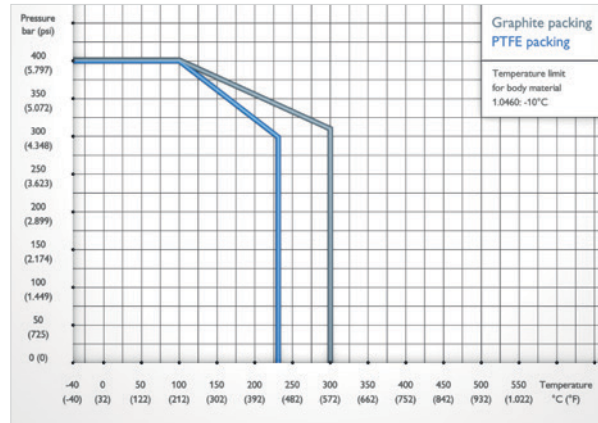

Needle Valves Type S338

Tube Fitting Connections Size S

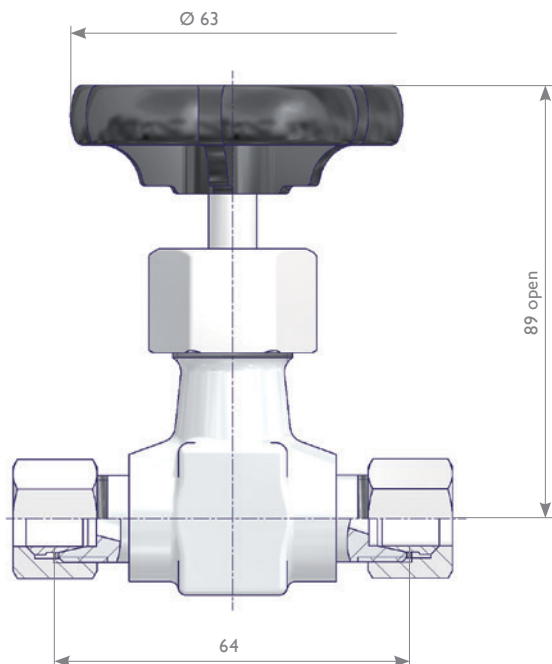

Inlet	Outlet	Part Number	
		Material 1.0460	Material 1.4571
6S		S338.03.130	S338.03.230
8S		S338.03.120	S338.03.220
10S		S338.03.110	S338.03.210
12S		S338.03.100	S338.03.200

Female Threads

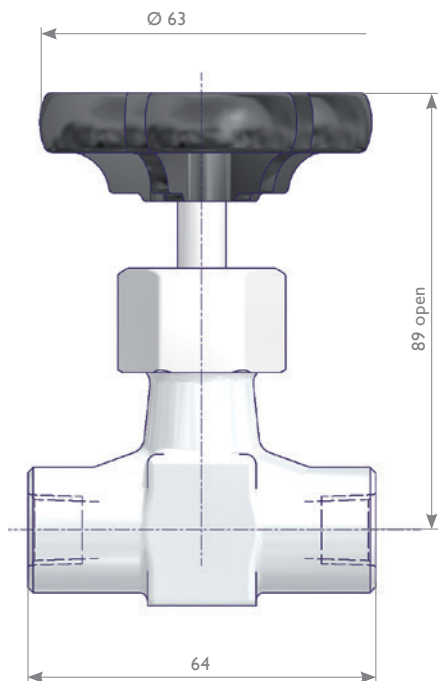

Inlet	Outlet	Part Number	
		Material 1.0460	Material 1.4571
1/4 NPT Female		S338.08.110	S338.08.210
G 1/4 Female		S338.08.115	S338.08.215
G 3/8 Female		S338.08.116	S338.08.216

Screwed Bonnet Needle Valves for Gas Service Type N334

Features

- Barstock Body - DN 5 / Bore Size 5 mm
- Screwed Bonnet
- Integral Valve Seat
- Internal Stem Thread
- Stem with cold rolled surface, back seat and non-rotating needle tip
- O-Ring Stem Seal in FPM

DVGW approved Valves:

- Basis of type examination: DVGW VP 308
- For all gases acc. to DVGW G260
- DVGW Registration-No.: DG-4315BP0209

Pressure-Temperature Rating:

- Max. 100 bar @ -20°C up to +60°C

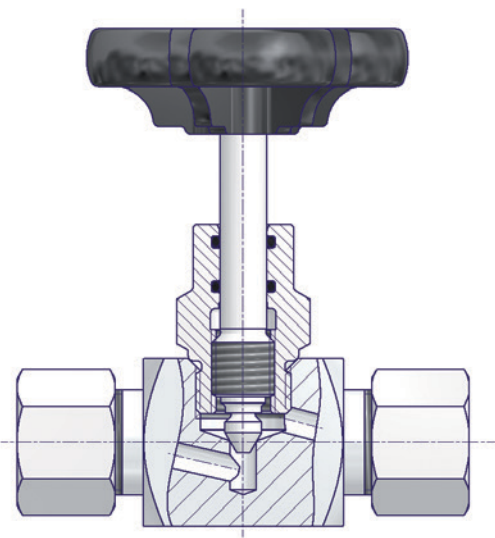

Components	Carbon Steel	Stainless Steel
	Material / Material No.	
Body	1.0460	1.4404
Bonnet	Brass	
Valve Stem	1.4104	
Needle Tip	1.4104	
Stem Seal	FPM	
Union Nut	Unalloyed Steel	1.4571
Single ferrule	Unalloyed Steel	1.4571
Handwheel	Plastic	

Needle Valve Type N334

DVGW tested and approved

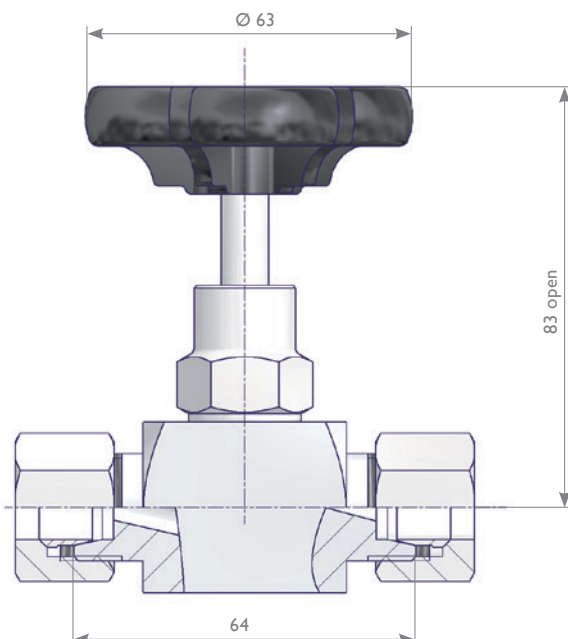

Connections	Surface Treatment	Part Number
Tube Fitting Sizes		
12L	Galvanized	N334.01.104.0083
12S	Galvanized	N334.01.114.0083

Needle Valves with threaded connections or weld ends are also available on request. Please contact the factory.

Screwed Bonnet Needle Valves Type S350 / S351

Features

- Forged Body - DN 8 / Bore Size 8 mm
- Screwed Bonnet
- Replaceable Valve Seat
- Stem with cold rolled surface, back seat and non-rotating needle tip

S350 with Internal Stem Thread

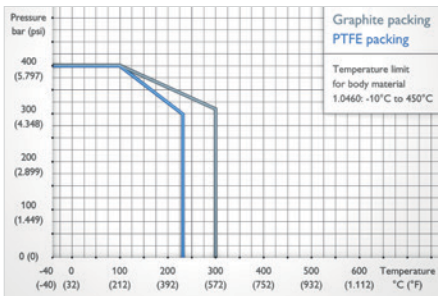
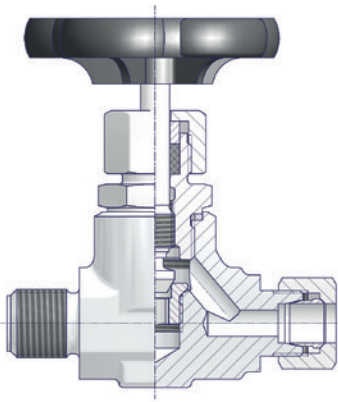

S351 with External Stem Thread*

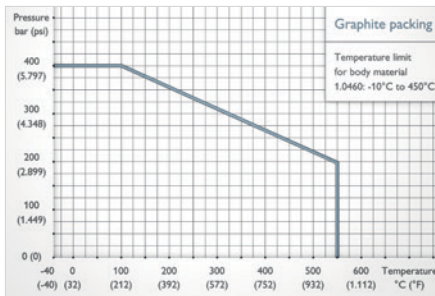
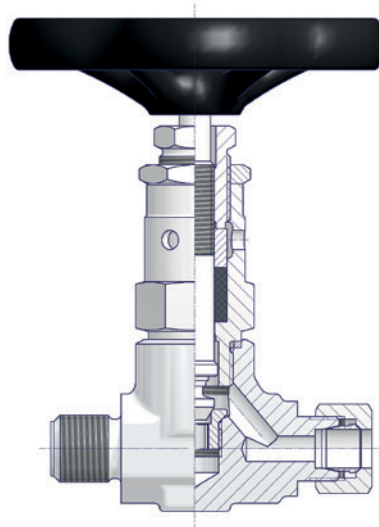

F350 Bellows sealed option*

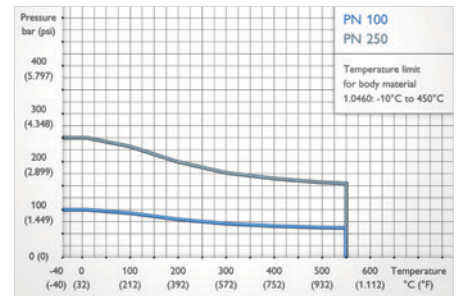
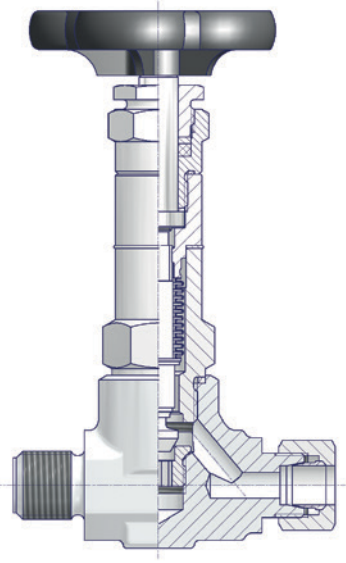

Components	Carbon Steel	Stainless Steel
	Material / Material No.	
Body	1.0460	1.4571
Bonnet	1.0501	
Valve Seat	1.4571	
Valve Stem	1.4104	
Needle Tip	1.4122	
Packing	PTFE (optional Graphite)	
Union Nut	Unalloyed Steel	1.4571
Tube Fittings		
Handwheel	Plastic	

Components	Carbon Steel	Stainless Steel
	Material / Material No.	
Body	1.0460	1.4571
Bonnet	1.7709	
Valve Seat	1.4571	
Valve Stem	1.4021	
Needle Tip	1.4122	
Packing	Graphite	
Stem Nut	Brass	1.4301
Union Nut	1.0501	1.4571
Single Ferrule	1.4571	
Handwheel	Unalloyed Steel	

Components	Carbon Steel	Stainless Steel
	Material / Material No.	
Body	1.0460	1.4571
Bonnet	1.4571	
Bellow		
Valve Seat		
Valve Stem	1.4571	
Needle Tip		
Packing	Graphite	
Stem Nut	1.4122	
Union Nut	1.0501	1.4571
Single Ferrule	1.4571	
Handwheel	Plastic	

* Temperature limit for Carbon Steel -10°C to 450°C.
Temperature limit for Single Ferrule Tube Fitting max. 400°C.

Needle Valves Type S350

Tube Fitting Connections Size S

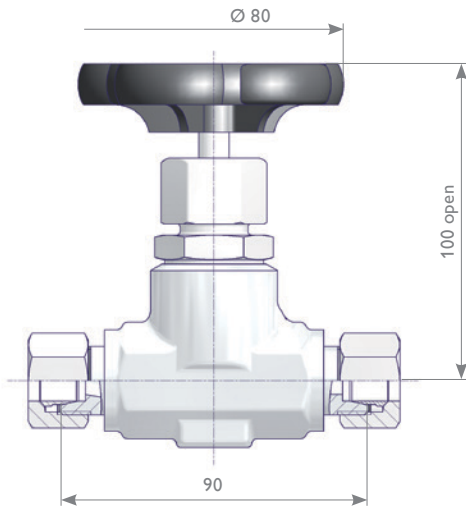

Inlet	Outlet	Material	Part Number
Tube Fitting Sizes			
12S		1.0460	S350.01.114
		1.4571	S350.01.214
14S		1.0460	S350.01.115
		1.4571	S350.01.215

Threaded Connections

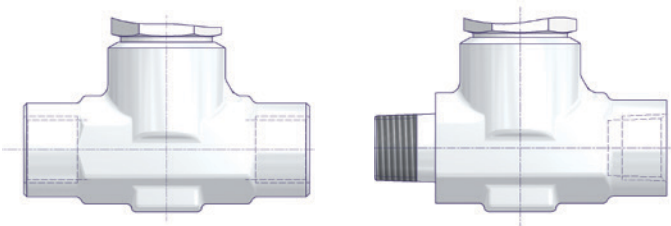

Inlet	Outlet	Material	Part Number
G 1/2 Female		1.0460	S350.03.104
		1.4571	S350.03.204
1/2 NPT Female		1.0460	S350.03.124
		1.4571	S350.03.224
1/2 NPT Male	1/2 NPT Female	1.0460	S350.07.124
		1.4571	S350.07.224

Male Threads DIN 19207 / Tube Fitting Connection*

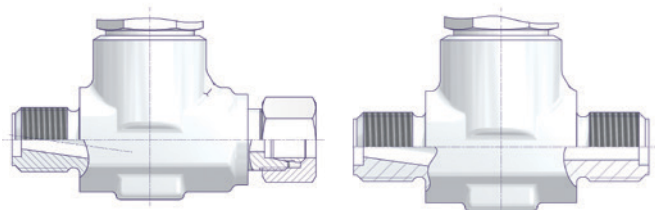

Inlet	Outlet	Material	Part Number
G 1/2 Male DIN 19207 – Type R	Tube Fitting Size 12S	1.0460	S350.07.114.06
		1.4571	S350.07.214.06
G 1/2 Male DIN 19207 – Type R		1.0460	S350.09.100.02
		1.4571	S350.09.200.02

* Max. operating pressure PN 160.

Weld Ends / Tube Fitting Connection

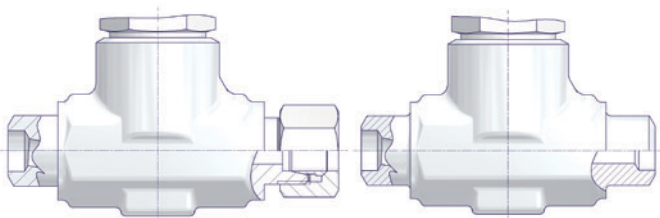

Inlet	Outlet	Material	Part Number
Weld End Ø 21.3 x Ø 12.2	Tube Fitting Size 12S	1.0460	S350.05.130
		1.4571	S350.05.230
Weld End Ø 21.3 x Ø 12.2		1.0460	S350.05.100
		1.4571	S350.05.200

Needle Valves Type S351

Tube Fitting Connections Size S

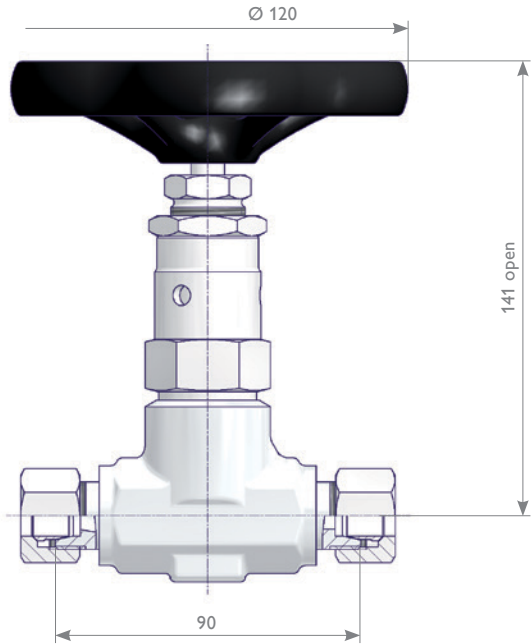

Inlet	Outlet	Material	Part Number
Tube Fitting Size			
12S		1.0460	S351.01.114
		1.4571	S351.01.214
14S		1.0460	S351.01.115
		1.4571	S351.01.215

Threaded Connections

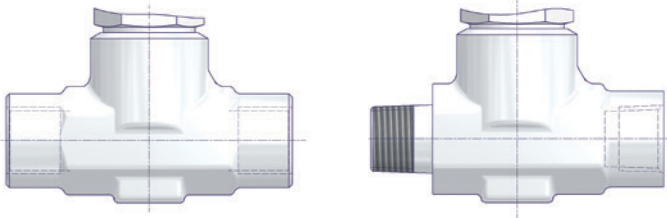

Inlet	Outlet	Material	Part Number
G 1/2 Female		1.0460	S351.03.104
		1.4571	S351.03.204
1/2 NPT Female		1.0460	S351.03.124
		1.4571	S351.03.224
1/2 NPT Male	1/2 NPT Female	1.0460	S351.07.124
		1.4571	S351.07.224

Weld Ends / Tube Fitting Connection

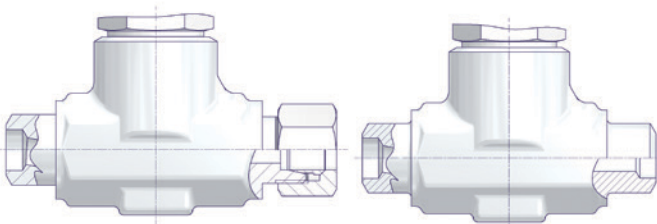

Inlet	Outlet	Material	Part Number
Weld End Ø 21.3 x Ø 12.2	Tube Fitting Size 12S	1.0460	S351.05.130
		1.4571	S351.05.230
Weld End Ø 21.3 x Ø 12.2		1.0460	S351.05.100
		1.4571	S351.05.200

Angle Needle Valves Type S360

Features

- Forged Body - DN 8 / Bore Size 8 mm
- Screwed Bonnet
- Integral Valve Seat
- Stem with cold rolled surface, back seat and non-rotating needle tip

Please contact the factory for Your Angle Pattern Needle Valve.

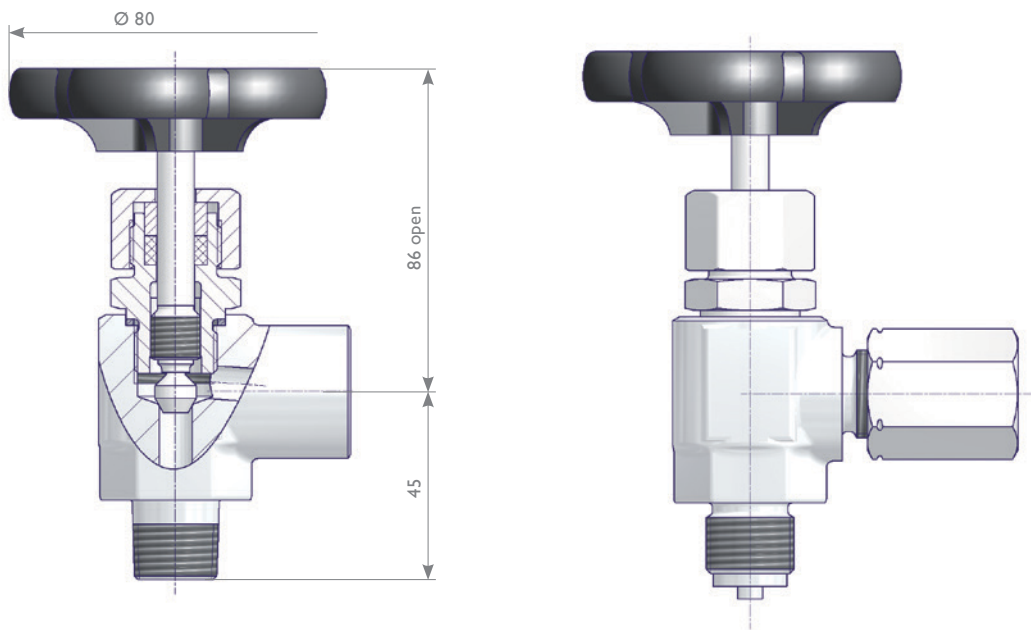

Components	Carbon Steel	Stainless Steel
	Material / Material No.	
Body	1.0460	1.4571
Bonnet	1.0501	
Valve Stem	1.4104	
Needle Tip	1.4122	
Packing	PTFE (Optional Graphite)	
Union Nut	Unalloyed Steel	1.4571
Tube Fitting		
Handwheel	Plastic	

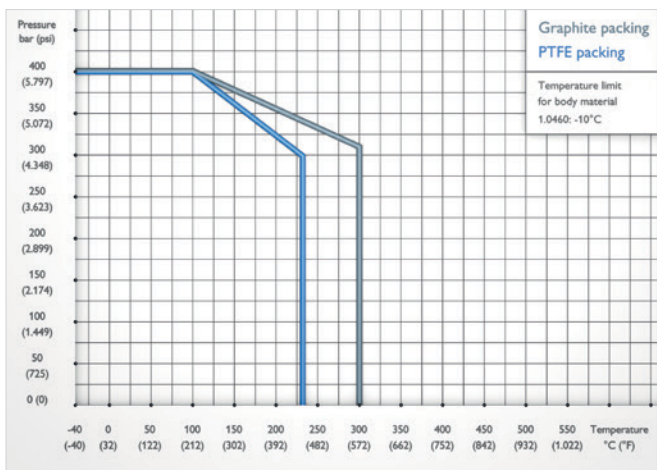

Y-Pattern Needle Valves Type S371

Features

- Forged Body - DN 8 / Bore Size 8 mm
- Screwed Bonnet
- Integral Valve Seat
- External Stem Thread
- Stem with cold rolled surface, back seat and non-rotating needle tip

Please contact the factory for Your Y-Pattern Needle Valve.

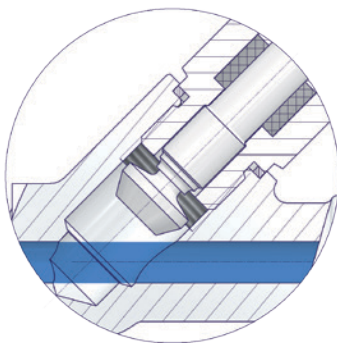

Straight-Through Design
→ Valve is fully roddable

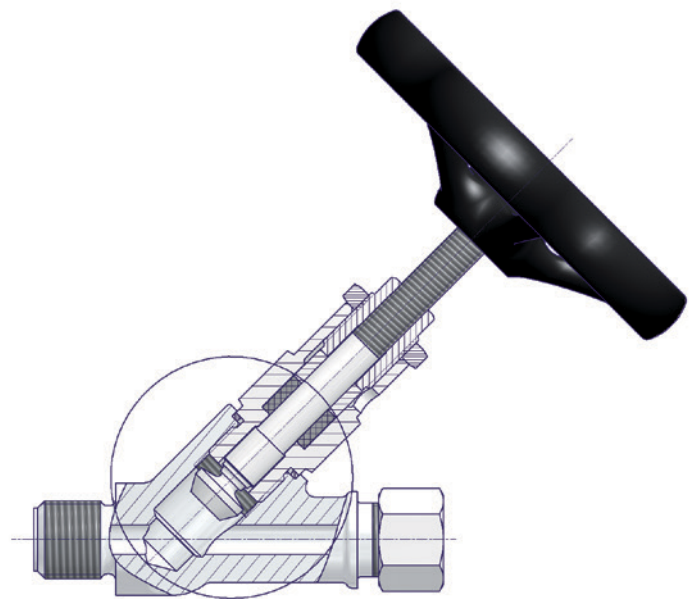

Components	Material / Material No.
Body	1.4571
Bonnet	
Valve Stem	
Needle Tip	
Packing	Graphite
Gland Nut	1.4301
Handwheel	Unalloyed Steel

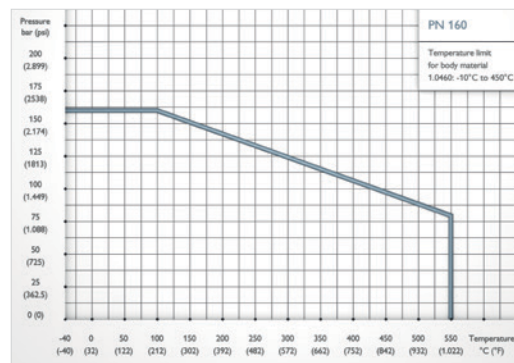

For working pressures exceeding 160 bar please contact the factory.

Screwed Bonnet Needle Valves Type S340 / S381

Features

- Forged Body - DN 8 / Bore Size 8 mm
- Screwed Bonnet
- Replaceable Valve Seat
- Stem with cold rolled surface, back seat and non-rotating needle tip

Needle Valve mainly used as Primary Isolation Valve.

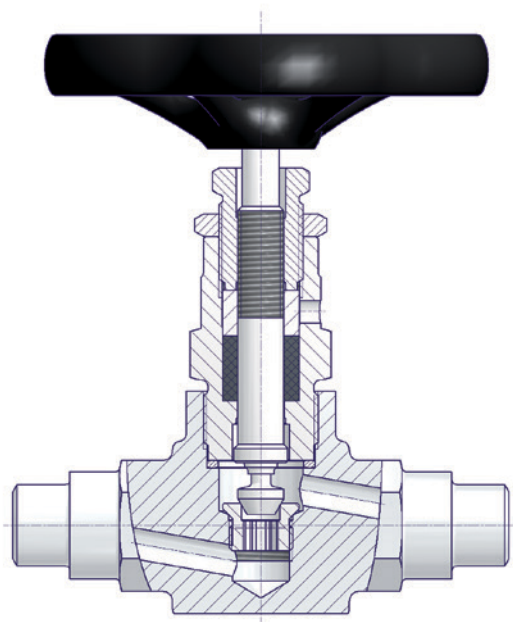

Components	Carbon Steel	Heat Resistant Steel		Stainless Steel
	Material / Material No.			
Body	1.0460	1.7335 / 1.5415	1.7383	1.4571
Bonnet	1.7709			
Valve Seat	1.4571		1.4981	
Valve Stem	1.4021		1.4571	
Needle Tip	1.4122		Stellite	
Packing	Graphite			
Stem Nut	Brass		1.4301	
Handwheel	Unalloyed Steel			

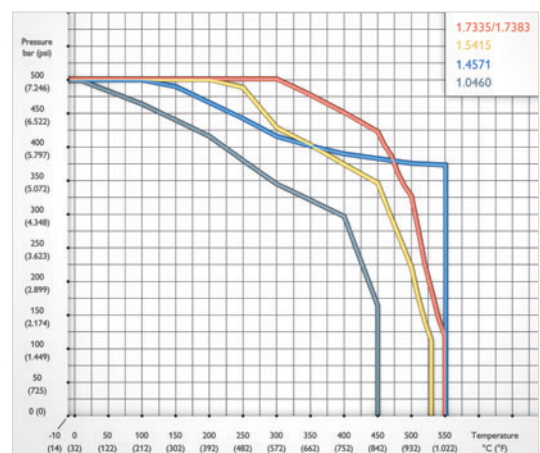

The respective maximum allowable pressure depends on the tube / pipe connection used. For further information please contact the factory.

Screwed Bonnet Needle Valves

Weld Ends

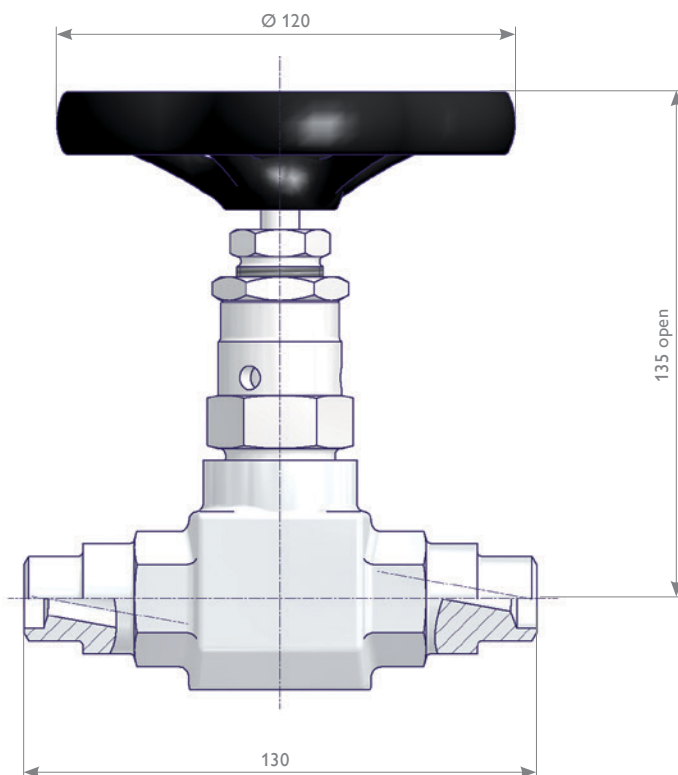

Weld End Connections		Part Number				
		Material				
Inlet	Outlet	1.0460	1.7335	1.5415	1.7383	1.4571
Tube Butt Weld End Ø 14 x 2.5		S340.11.112.04	S340.11.114.04	S340.11.600.11	S340.16.112.04	S340.11.212.04
Pipe Butt Weld End Ø 21.3 x 3.2		S340.11.135.31	S340.11.136.31	S340.11.636.31	S340.16.136.31	S340.11.236.31
Pipe Butt Weld End Ø 21.3 x 2.9		S340.11.135.32	S340.11.136.32	S340.11.636.32	S340.16.136.32	S340.11.236.32
Pipe Butt Weld End Ø 21.3 x 3.2	Tube Butt Weld End Ø 14 x 2.5	S340.11.135.33	S340.11.136.33	S340.11.636.33	S340.16.136.33	S340.11.236.33
Pipe Butt Weld End Ø 21.3 x 2.9	Tube Butt Weld End Ø 14 x 2.5	S340.11.135.34	S340.11.136.34	S340.11.636.34	S340.16.136.34	S340.11.236.34
Pipe Butt Weld End Ø 21.3 x 6.3	Tube Butt Weld End Ø 14 x 2.5	S340.11.135.37	S340.11.136.37	S340.11.636.37	S340.16.136.37	S340.11.236.37
Pipe Butt Weld End Ø 24 x 7.4	Tube Butt Weld End Ø 14 x 2.5	S340.11.135.40	S340.11.136.40	S340.11.636.40	S340.16.136.40	S340.11.236.40
Pipe Socket Weld End 1/2"		S381.40.114.01	S381.40.614.01	S381.40.714.01	S381.40.514.01	S381.40.214.01

Union Bonnet Needle Valves Type A1

Features

- Barstock Body - DN 11 / Bore Size 11 mm
- Union Bonnet
- Integral Valve Seat
- External Stem Thread
- Valve Stem with cold rolled threads
- Non-rotating Needle and back seat design

Options see Ordering Information on Page 23.

Union Bonnet Needle Valves are designed for Severe Service.

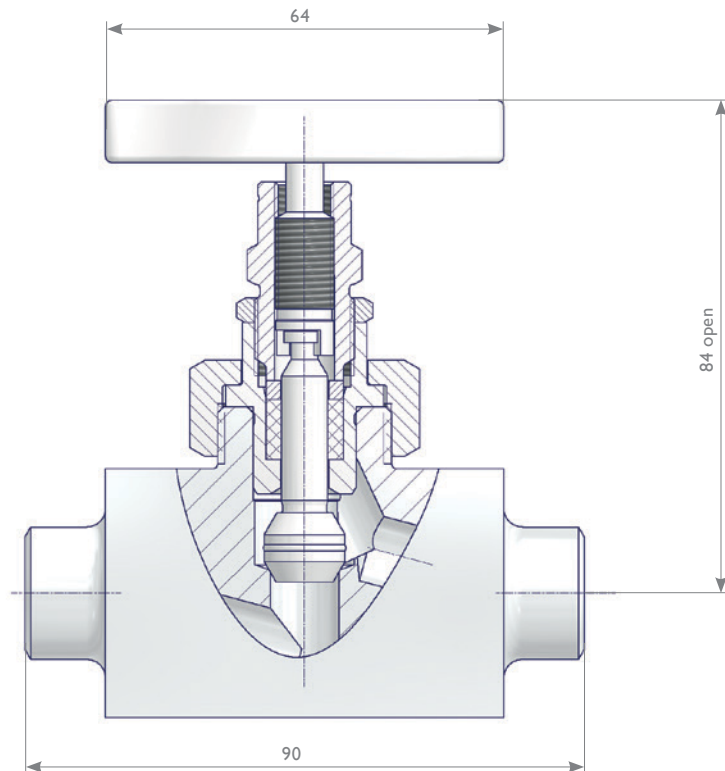

Components	Heat Resistant Steel	Stainless Steel
	Material / Material No.	
Body	1.4903 / F91*	316H
Bonnet	1.4903 / F91	316 / 316L
Valve Stem	1.4404 / 316L	
Needle	1.4923 - Tip Stellite	316 / 316L
Union Nut	1.7709	316 / 316L
Packing	PTFE or Graphite	
Stem Nut	316	
T Bar Handle	Options see Ordering Information	

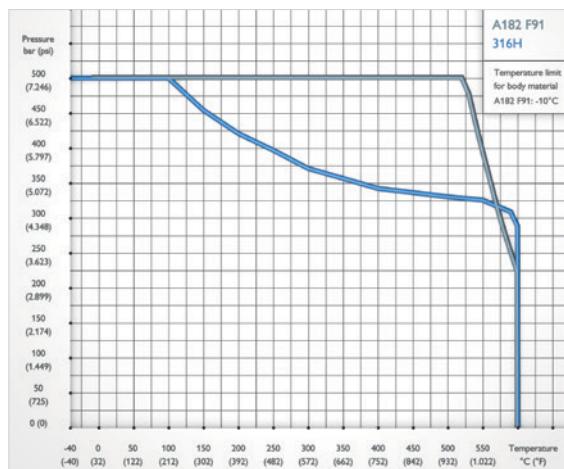

PTFE Packing is limited to 232°C (450°F).

The respective maximum allowable pressure depends on the tube / pipe connection used. For further information please contact the factory.

* Welded connections in material 1.4903 / F91 / 1.7335 / 1.7380 require post weld heat treatment (PWHT) at around 700 - 750°C. The valve head unit must be removed prior to the heat treatment to avoid damages. See the installation, operation and maintenance manual for instructions. We recommend to order these valves with 100 mm pipe extensions (Option V - Box 15) to avoid the removal of the valve head units.

Union Bonnet Tandem Valves Type B1

Features

- Barstock Body DN 8 / Bore Size = 8 mm
- Union Bonnet
- Integral Valve Seat
- External Stem Thread
- Valve Stem with cold rolled threads
- Non-rotating Needle and back seat design

Options see Ordering Information on Page 23.

Union Bonnet Tandem Valves are designed for Severe Service.

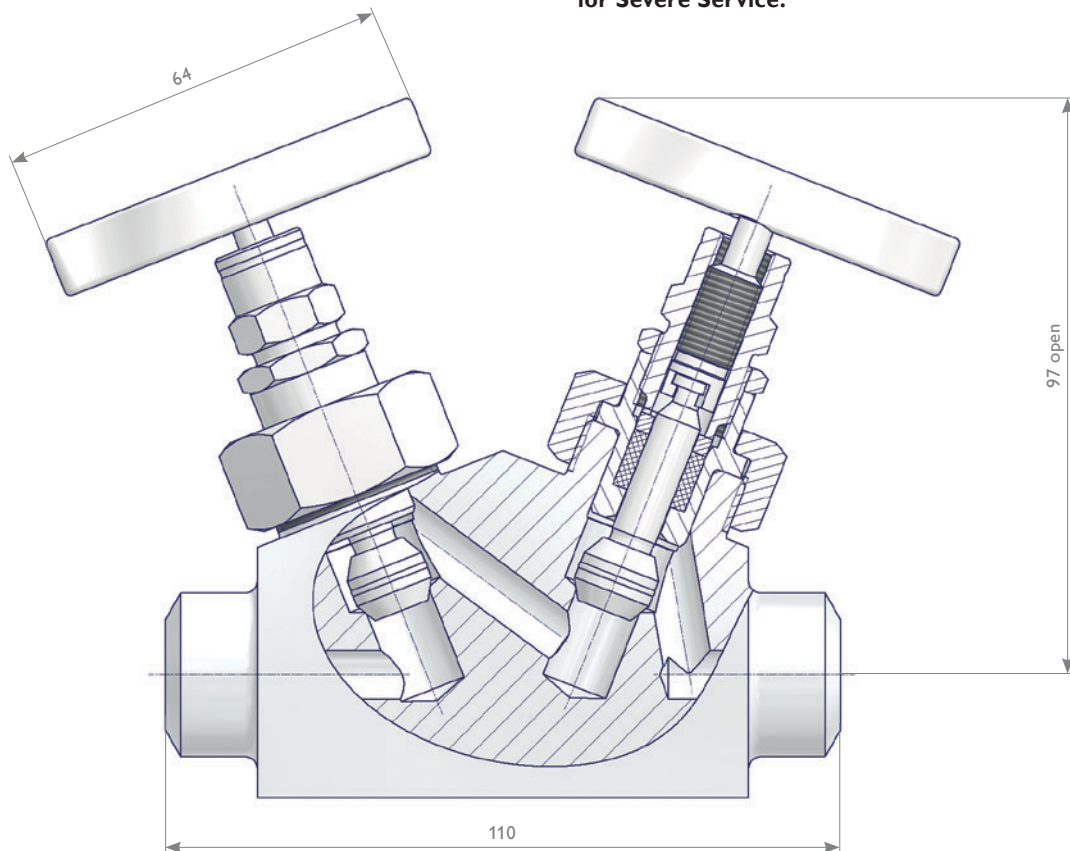

Components	Heat Resistant Steel				Stainless Steel
	Material / Material No.				
Body	1.4903 / F91*	1.5415	1.7335*	1.7380*	316 / 316L
Bonnet	1.4903 / F91				316 / 316L
Valve Stem	1.4404 / 316L				
Needle	1.4923 - Tip Stellite				316 / 316L
Union Nut	1.7709				316 / 316L
Packing	PTFE or Graphite				
Stem Nut	316				
T Bar Handle	Options see Ordering Information				

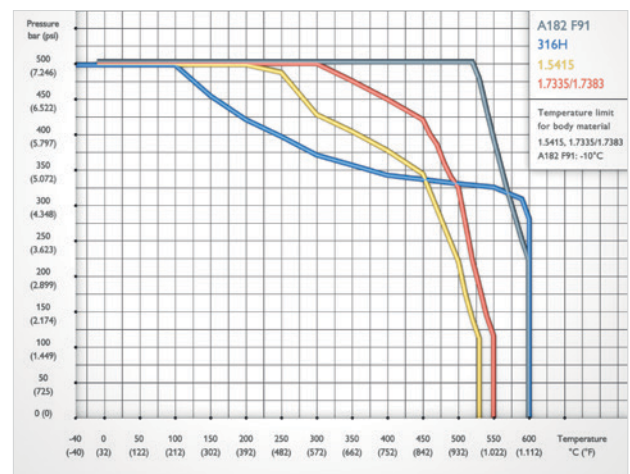

PTFE Packing is limited to 232°C (450°F).

The respective maximum allowable pressure depends on the tube / pipe connection used. For further information please contact the factory.

* Welded connections in material 1.4903 / F91 / 1.7335 / 1.7380 require post weld heat treatment (PWHT) at around 700 - 750°C. The valve head unit must be removed prior to the heat treatment to avoid damages. See the installation, operation and maintenance manual for instructions. We recommend to order these valves with 100 mm pipe extensions (Option V - Box 15) to avoid the removal of the valve head units.

Bolted Bonnet Needle Valves Type A2

Features

- Barstock Body - DN 20 / Bore Size 20 mm
- Bolted Bonnet
- Integral Valve Seat
- External Stem Thread
- Valve Stem with cold rolled threads
- Non-rotating Needle and back seat design

Options see Ordering Information on Page 23.

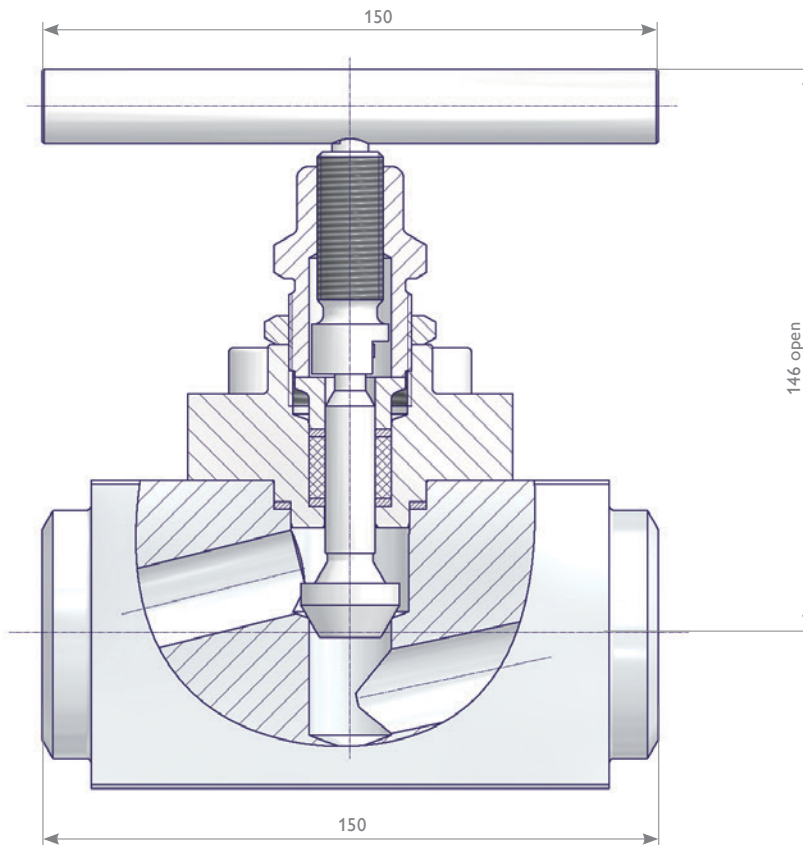

Components	Heat Resistant Steel	Stainless Steel
	Material / Material No.	
Body	1.4903 / F91	316 / 316L
Bonnet	1.4903 / F91	316 / 316L
Body-Bonnet Seal	Graphite	
Valve Stem	S17400	
Needle	1.4923 - Tip Stellite	316 / 316L
Bonnet bolting	1.4980 / A453 Gr.660 Cl.B	
Packing	PTFE or Graphite	
Stem Nut	1.4301 / 304	
T Bar Handle	Options see Ordering Information	

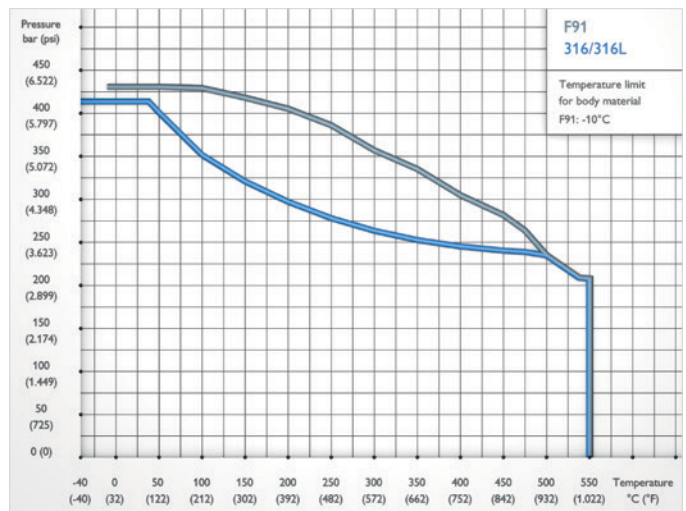

PTFE Packing is limited to 232°C (450°F).

The respective maximum allowable pressure depends on the tube / pipe connection used. For further information please contact the factory.

Welded Bonnet Needle Valves Type A4

Features

- Barstock Body - DN 10 / Bore Size 10 mm
- Electron Beam Welded Bonnet
- Extended Bonnet to dissipate heat and to lower heat at the packing and the stem threads
- Integral Valve Seat
- External Stem Thread
- Non-rotating Stem with cold rolled surface and back seat design

Options see Ordering Information on Page 23.

Needle Valve for High Temperature Service.

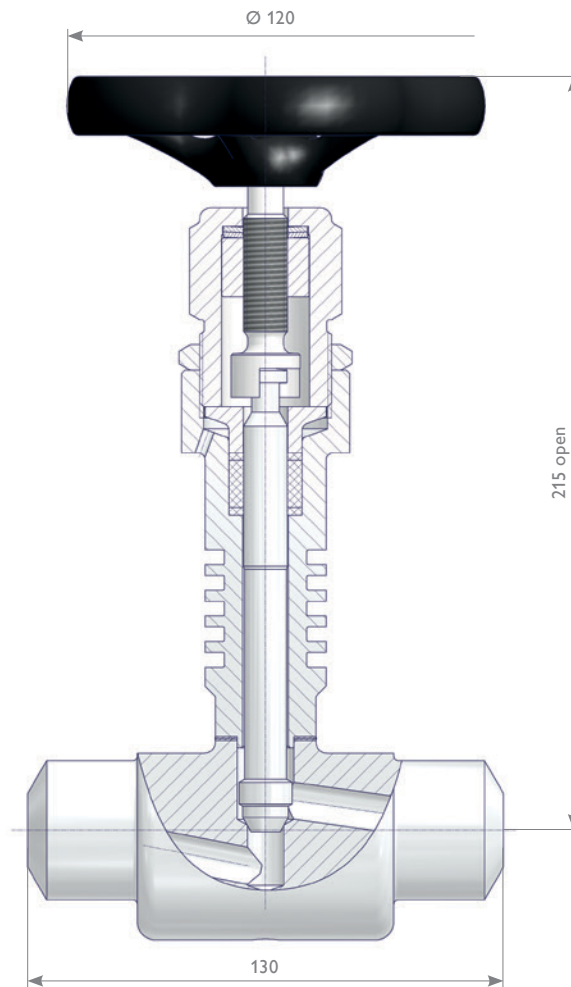

Components	Heat Resistant Steel	Stainless Steel
	Material / Material No.	
Body	1.4901	1.4981
Bonnet	1.4901	1.4981
Valve Stem	1.4923	
Needle	Alloy 80A	
Packing	Graphite	
Stem Nut	1.4571	
T Bar Handle	Options see Ordering Information	

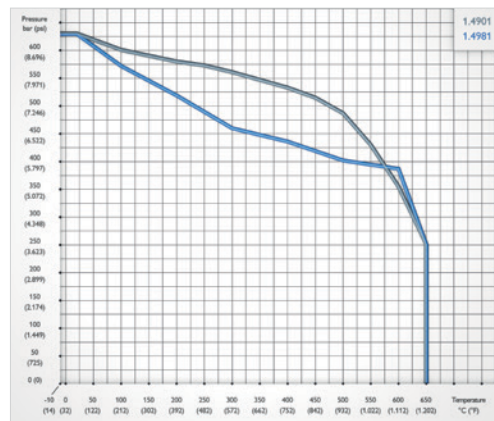

Graphite Packing only.

Ordering Information I A1, B1, A2 and A4 Needle Valves

Ordering Information

				1	2	3	4	5	6	7	8	9	10	11	12	13	14	15	
				B	1	B	-	A	4	P	A	4	P	-	S	A	K		
Valve Type																			
A1	Union Bonnet Needle Valve DN 11 / Bore Size 11 mm																		
B1	Union Bonnet Tandem Valve DN 8 / Bore Size 8 mm																		
A2	Bolted Bonnet Needle Valve DN 20 / Bore Size 20 mm																		
A4	Welded Bonnet Needle Valve DN 10 / Bore Size 10 mm (Graphite Packing only.)																		
Packing																			
A	PTFE																		
B	Graphite																		
W	Carbon-Filled PTFE – TA-Luft																		
Inlet Connection																			
A	Butt Weld End																		
D	Socket Weld End																		
H	Twin Ferrule Tube Fitting																		
L	Female Thread																		
Pipe / Tube				Tube Fitting				Thread											
4	1/2" pipe			R	Rotarex			N	NPT										
6	3/4" pipe*1			S	Swagelok														
8	1" pipe*1																		
C	10 mm																		
D	12 mm																		
E	14 mm																		
F	16 mm																		
G	18 mm																		
K	25 mm*1																		
T	1" tube*1																		
V	1 1/4" tube*1																		
X	1 1/2" tube*1+2																		
Wall Thickness Pipes / Tubes				Tube O.D.				Thread Size											
2	2.0 mm			4	12			4	1/2"										
3	3.2 mm			5	14														
4	4.0 mm			6	16														
8	2.6 mm																		
A	3.6 mm																		
D	5.0 mm																		
E	5.5 mm																		
G	7.0 mm																		
N	Schedule 40																		
P	Schedule 80																		
Q	Schedule 160																		
A	Socket Weld																		
Outlet Connection → see Inlet Connection Ordering Information Specifics																			
Body Material																			
	A1	B1	A2	A4															
R	-	1.7335	-	-															
S	316H	316/316L	316/316L	-															
U	-	1.7380	-	-															
W	F91	F91	F91	-															
Q	-	1.5415	-	-															
X	-	-	-	1.4981															
Y	-	-	-	1.4901															
Vent Connection																			
A	Without																		
Operation Options																			
B	Handwheel Unalloyed Steel																		
K	T Bar Handle																		
Additional Options																			
V	Pipe Extension																		

*1 Socket Weld End for A2 Needle Valve only.

*2 Butt Weld End not available for A1 Needle Valve.

Armaturenfabrik Franz Schneider GmbH + Co.KG reserves the right to change materials, specifications or designs without notice.

Condensate Pots

Product Description

Condensate Pots (also called Seal Pots) are used in the measurement of steam or other vapors for two reasons: One reason is that a level of condensed water is accumulated inside of the pot and maintains a fluid volume for displacement equal to or greater than the volume displacement of the transmitter (protecting the transmitter from heat).

The second reason for maintaining a liquid inside of the pot is to prevent flashing of the liquid in the impulse line if a sudden temperature change of the steam is made. A dam inside of the pot prevents this flashing effect.

Pots with more outlet ports for applications where foreign material should be trapped and drained preventing damage of the manifolds and transmitters are also available. Please contact the factory. For details see also DIN 19211.

Condensate Pots for Small Volume Displacements

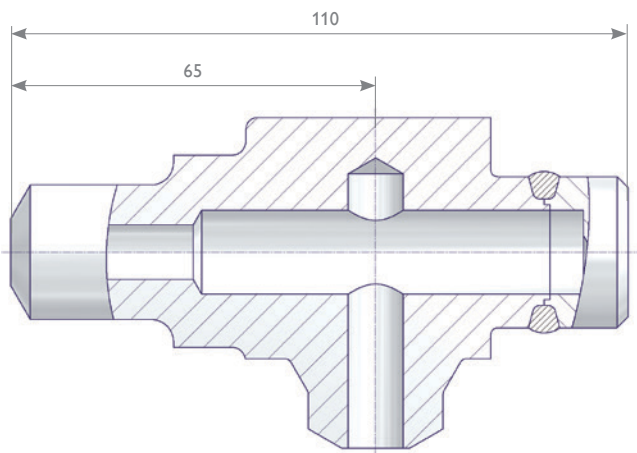

Optional

Condensate Pot / Primary Isolation Valve Assembly - Factory Welded

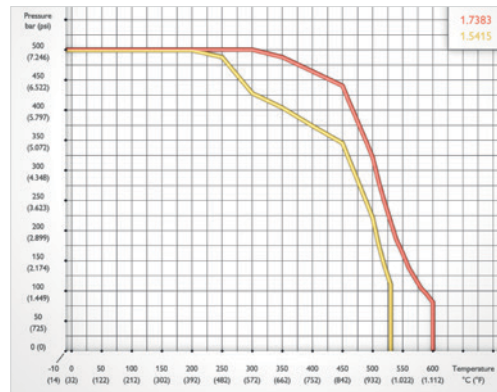
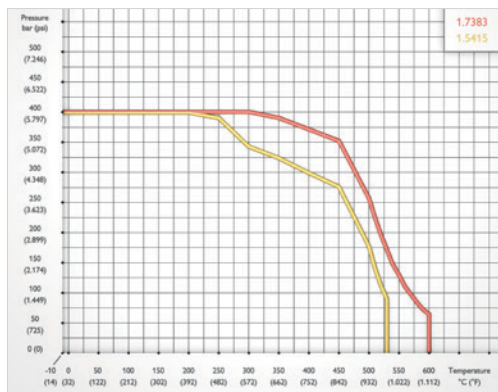
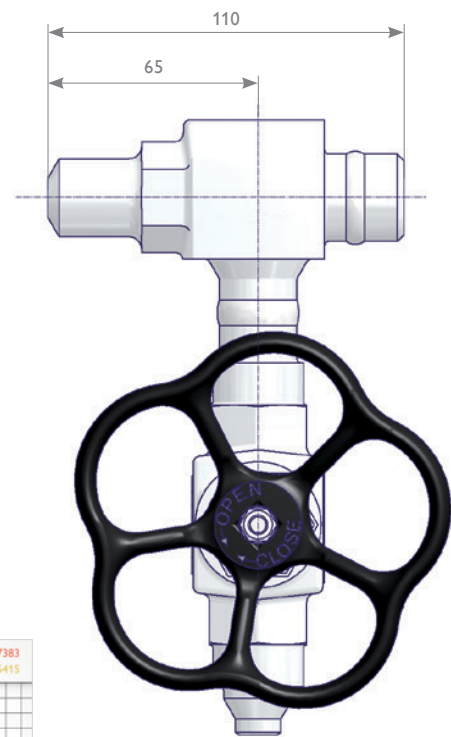

Weld End Connections		Part Number		
		Material		
Inlet	Outlet	1.5415		1.7383
		PN	Volume (approx.)	
			20 cm ³	20 cm ³
Pipe Butt Weld End Ø 21.3 x 3.2		400	S007.51.603.42	
Pipe Butt Weld End Ø 21.3 x 6.3		500	S007.51.600.45	
Pipe Butt Weld End Ø 24 x 7.1		500	S007.51.600.26	S007.51.500.26

Condensate Pots for Larger Volume Displacements

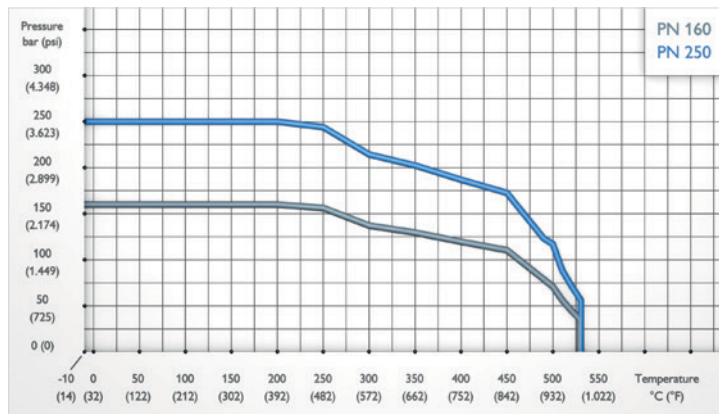
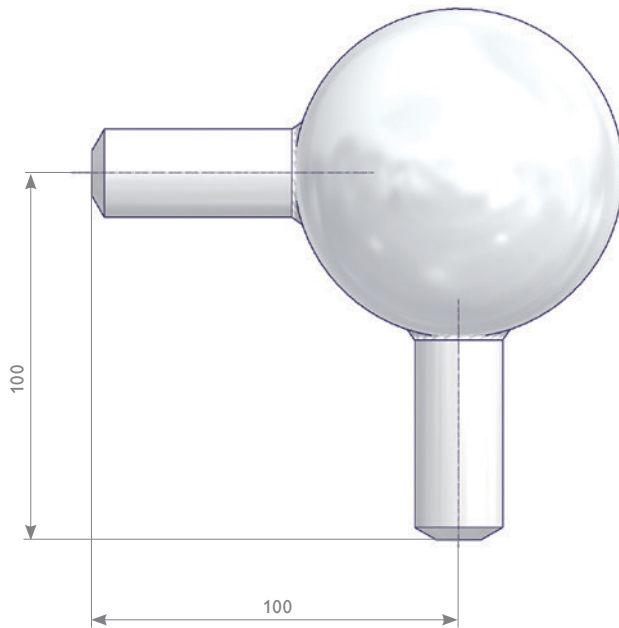

Weld End Connections		Part Number		
		Material 1.5415		
Inlet	Outlet	PN	Volume	
			250 cm ³	700 cm ³
Pipe Butt Weld End Ø 21.3 x 6.3		250	S007.51.653.05	
Pipe Butt Weld End Ø 33.7 x 4.5	Pipe Butt Weld End Ø 24 x 7.1	250		S007.51.653.06
G 1/2 Male DIN 19207 Type R	G 1/2 Male DIN 19207 Type V	160	S007.51.653.04	

Weld Fittings | Tees, Reducers, Connectors

Product Description

AS-Schneider is providing a large range of Weld Fittings – different concerning shape (Tees, Elbows, etc.) and connections (for pipes and tubes) and different in terms of available materials. On this page we are just showing the most used types.

If you don't find your option please contact the factory.

Tees

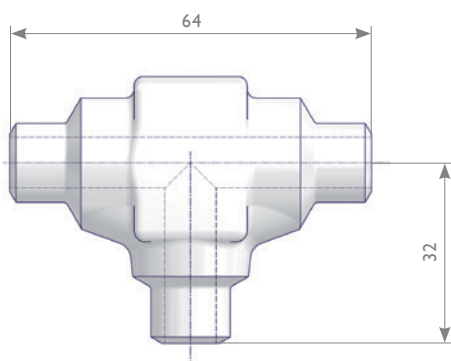

Weld End Connections	Part Number		
	Material		
	1.5415	1.7335	1.4571
Pipe Butt Weld End Ø 21.3 x 3.2	S006.40.610.43		S006.40.210.43
Tube Butt Weld End Ø 14 x 2.5	S006.40.600	S006.40.101	S006.40.200
Tube Socket Weld End Ø 14			S006.40.210

Reducers (Pipe Butt Weld x Tube Butt Weld)

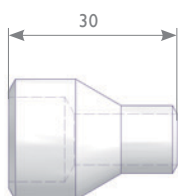

Weld End Connections		Part Number	
		Material	
		1.5415	1.4571
Pipe Butt Weld End Ø 21.3 x 3.2	Tube Butt Weld End Ø 12 x 1.5		S006.40.230.20
Pipe Butt Weld End Ø 21.3 x 3.2	Tube Butt Weld End Ø 14 x 2.5	S006.40.630.14	S006.40.230.14
Pipe Butt Weld End Ø 33.7 x 4.5	Tube Butt Weld End Ø 14 x 2.5	S006.40.632.84	S006.40.232.84

Connectors (Pipes and Tubes)

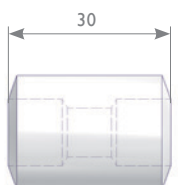

Weld End Connections	Part Number	
	Material	
	1.5415	1.4571
Weld End Ø 21.3 x Ø 12.2		S006.40.220
Weld End Ø 21.3 x Ø 14.25	S006.40.120.04	S006.40.220.04

Threaded Pipe Ends acc. to DIN 19207

Product Description

DIN 19207 is defining 2 different Threaded Connections (Type V and Type R) to be used either for a Flanged Connection with Threaded Flanges or a Nipple Connection. For more details see DIN 19207. The max. operating pressure for this connection is defined at 160 bar.

Valves with DIN 19207 connections see Page 13, condensate pots see Page 25.

Flange Connection I Accessory Kit

Mounting Kit contains	Material	Part Number
4 Hexagon Nuts DIN EN ISO 4032 - M10 4 Hex Cap Screws DIN EN ISO 4014 - M10 x 45	Carbon Steel Nuts and Screws 1.1181, Gasket 1.4571, Flange 1.0460	S006.39.100.02
1 Grooved Gasket DIN 19207 - B 1/2 2 Threaded Flanges DIN 19207 - G 1/2	Stainless Steel Nuts A4-70, Screws A2-70, Gasket 1.4571, Flange 1.4571	S006.39.200.02

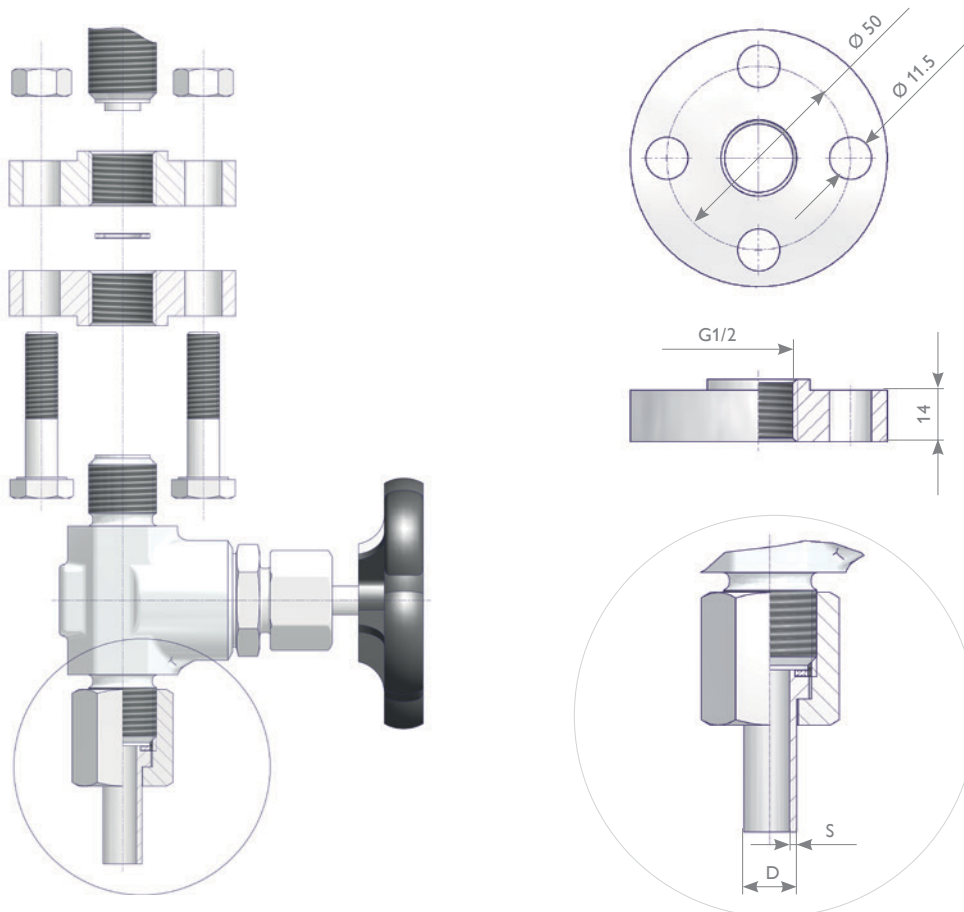

Nipple Connection I Accessory Kit

Union Nut		Nipple		Grooved Gasket	Accessory Kit
Thread	Material	D	s	Material	Part Number
G 1/2	1.1181	12	1.65	1.4571	S007.45.103.10
	1.4571				S007.45.203.10
	1.1181	14	2.5		S007.45.103.11
	1.4571				S007.45.203.11



schneider

Tailored to Your Business



**Armaturenfabrik Franz Schneider
GmbH + Co. KG**

Bahnhofplatz 12 | 74226 Nordheim
Deutschland / Germany

Tel: +49 71 33 101-0

Fax: +49 71 33 101-148



www.as-schneider.com



AS-Schneider Asia-Pacific Pte. Ltd.

970 Toa Payoh North, #02-12/14/15
Singapore 318992

Tel: +65 6251 3900

Fax: +65 6251 3990



www.as-schneider.sg



**Armaturenfabrik Franz Schneider
SRL**

Str. Mihai Viteazu, Nr. 327i | 507085 Harman
Jud. Braşov | Romania

Tel: +40 368 41 40 25

Fax: +40 368 41 40 26



www.as-schneider.ro



AS-Schneider Middle East FZE

P.O. Box 18749 | Dubai
United Arab Emirates

Tel: +971 4 880 85 75

Fax: +971 4 880 85 76



www.as-schneider.ae



AS-Schneider America, Inc.

17421 Village Green Dr | Houston, TX 77040
United States of America



www.as-schneider.com