

Catalog 4123-EA
Revised, January 2001



Electric Actuators

Introduction

Parker 70 and 80 Series Electric Actuators are designed for electric actuation of Parker's B Series, MB Series, HB Series, and SB Series Ball Valves. They provide reliable, cost effective, remote valve actuation. The simplicity of design provides accessible and easy wiring installation. The convenience and accuracy of advanced modular electronics gives the user the ability to wire in accessories without all the hard wiring hassles. The master PC ("mother") board accepts plug-in modular ("daughter") boards to allow for a variety of accessory functions. Other than connecting a power source, there is no internal wiring to tangle with, ever. With a variety of accessories as well as superior actuator design, Parker's Ball Valves with the 70 or 80 Series actuators are the obvious choice.

70 SERIES

Specifications

- Voltage: 24, 115 or 230 VAC (50/60 Hz); 12 or 24 VDC
- Torque: 150, 300, 600 in lb (17, 34, 68 N m)
- Enclosure: PVC composite
- Duty cycle: 25%; 100% (VDC models)
- Actuator bolt pattern: ISO standard (5211)
- Conduit connection: 1/2" NPT
- Output shaft: Male, zinc plated steel
- Temperature limits (all models): 32 °F to 150 °F (0 °C to 66 °C); (-40 °F [-40 °C] minimum with heater and thermostat)

Features

- Single direction actuation
- PVC cover resists damage/UV radiation
- NEMA 4 (weatherproof), 4X (weatherproof with corrosion resistance)
- Hardened steel spur gear drive train provides consistent, long life performance
- Permanently lubricated gear train and bearings
- Low profile design/direct drive male output permit limited space installation
- Available for the B Series, MB Series, HB Series and SB Series ball valves
- Available for 2-way (90°) and 3-way (180°) configurations
- Approximate weight: 6 lb (2.7 kg)
- CSA certified
- Limit Switch: Single pole, double throw, rated for 1/3 HP, 10 amps @ 125/230 VAC, CSA certified

Options

- Additional limit switch and cam
- Heater and thermostat (For operation to -40 °F [-40 °C])
- CE (European Conformity) marking available

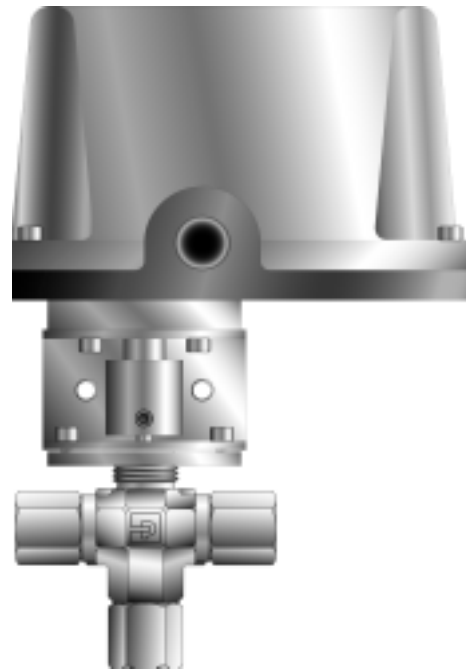

Model Shown: 4F-B6XJ-SS-71XA

70R Series

Specifications

- Same as 70 series

Features

- Bi-directional (reversing) actuation
- Declutchable manual override (output shaft extends out of the cover)
- Valve position indication

Added Options

- Additional limit switches and cams (specify up to 2)
- Position indicator

Materials of Construction

Part	Material
Cover	Composite, PVC
Base	Diecast zinc alloy
Gear Train	Hardened steel
Output Shaft	Zinc plated steel
Finish	Powder coated epoxy

80 SERIES

Specifications

- Voltage: 24, 115 or 230 VAC (50/60 Hz); 12 or 24 VDC
- Torque: 150, 300, 600, 1000 in lb (17, 34, 68, 113 N m)
- Enclosure: Epoxy coated cast aluminum
- Duty cycle: 75%; 100% (VDC models)
- Actuator bolt pattern: ISO standard (5211)
- Conduit connection: 1/2" NPT (2 places)
- Output drive: ISO compatible female drive output
- Temperature limits (all models): 32 °F to 150 °F (0 °C to 66 °C); (-40 °F [-40 °C] minimum with heater and thermostat)

Features

- Bi-directional actuation
- Mother/daughter board, modular electronics technology
- Circuit board readily accepts plug-in connectors
- Variety of plug-in accessory boards are available
- Easy installation, no hard-wiring required
- NEMA 4 (weatherproof), 4x (weatherproof with corrosion resistance), NEMA 7 (explosion proof, gases) & 9 (explosion proof, dust) - Class I, Div. I, Group C&D; Class I, Div. II, Group E, F, and G
- Highly efficient spur gear power train
- Lubrication: Permanently lubricated gear train and bearings
- Manual override
- Visual position indicator
- Available for the B Series, MB Series, HB Series and SB Series ball valves
- Available for 2-way (90°) and 3-way (180°) configurations
- Approximate weight: 17 lb (7.7 kg)
- CSA certified
- Limit Switch: Single pole, double throw, rated for 1/3 HP, 10 amps @ 125/230 VAC, CSA certified

Standard Options

- Additional limit switches and cams (specify up to 2)
- Heater and thermostat (For operation to -40 °F [-40 °C])
- Modulating control package with position re-transmit (4-20mA, 0-10 VDC, includes potentiometer)
- CE (European Conformity) marking available

Additional 80 Series Options (consult the factory)

- Timer
- Cycle rate regulator (CRR)
- Center off
- Mechanical brake
- Potentiometer
- Relay board
- Dual relay board
- Declutchable handwheel
- Fail-safe Options: battery or capacitance type

TESTING

Actuator

All 70 and 80 Series Electric Actuators are factory tested for accurate cycle times and correct output signals at all applicable positions.



Model Shown: 4W-SB8L-UPE-SS-81CS2

Materials of Construction

Part	Material
Cover	Diecast aluminum alloy
Base	Diecast aluminum alloy
Gear Train	Hardened steel
Output Shaft	N/A
Finish	Powder coated epoxy

Valve

All valves are factory tested for internal and external leakage as described in their respective catalogs.

Valve / Actuator Assemblies

All valve/actuator assemblies are factory tested for proper valve actuation.

Electric Actuators

70 SERIES

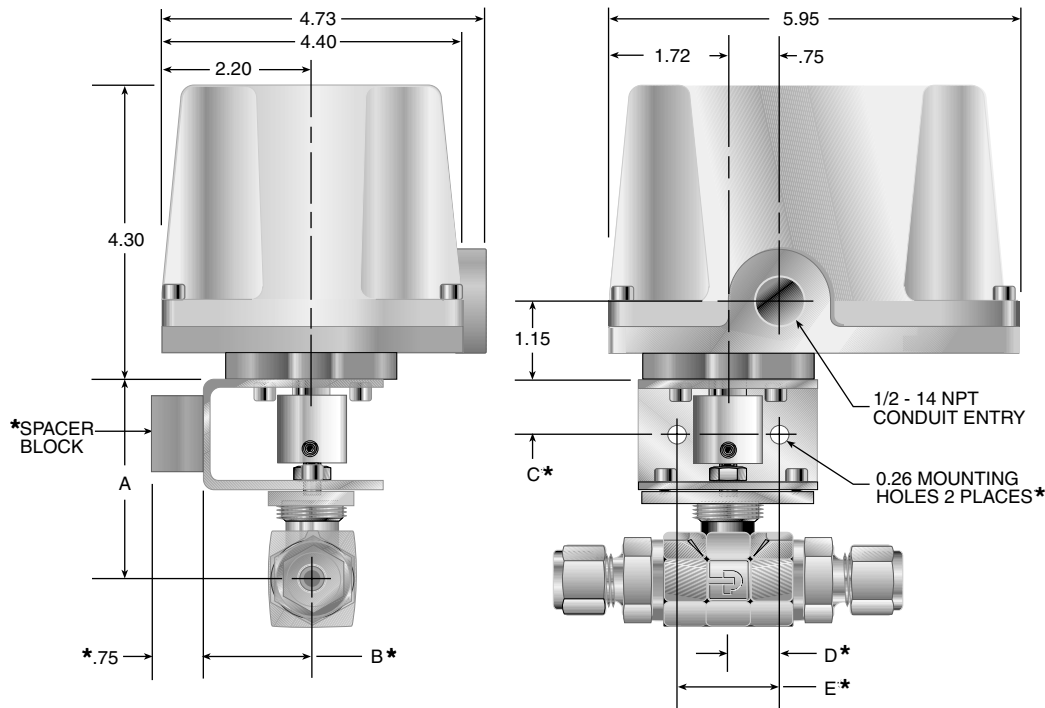

Dimensional Data

Valve Type	A		B*		C*		D*		E*	
	Inch	mm	Inch	mm	Inch	mm	Inch	mm	Inch	mm
B2	2.23	56.6								
B6	2.49	63.2								
B8	2.91	73.9								
MB2	2.33	59.2	1.61	40.9	0.80	20.3	0.75	19.1	1.50	38.1
MB4	2.33	59.2								
MB6	2.48	63.0								
HB4	2.70	68.6								
SB8	2.94	74.7								
SB12	3.03	77.0								
SB16	3.27	83.1	N/A	N/A	N/A	N/A	N/A	N/A	N/A	N/A
SB20	3.46	87.9								
SB24	3.73	94.7								
SB32	3.92	99.6								

*Not applicable with SB Series Ball Valves

Actuator Model	Breakaway Torque in lb (N m)	Voltage	Duty Cycle	Cycle Time (sec)	Amps at stall (Nominal)			Approx. Weight lb (kg)
					24 VAC	115 VAC	230 VAC	
71	150 (17.0)	24 VAC, 115 VAC or 230 VAC	25%	5	5.2	1.3	0.7	6 (2.7)
72	300 (34.0)			9	7.2	1.8	0.9	
73	600 (67.8)			16	7.2	1.3	0.7	

Actuator Model	Breakaway Torque in lb (N m)	Voltage	Duty Cycle	Cycle Time (sec)		Amps at Running Torque (Nominal)		Approx. Weight lb (kg)
				12 VDC	24 VDC	12 VDC	24 VDC	
72	300 (34.0)	24 VDC	100%	**	9	**	0.5	6 (2.7)
73	600 (67.8)	12 VDC or 24 VDC		16	16	1.3	0.5	

NOTE: Cycle times reflect 90° rotation. For 180° rotation, double the cycle time.

**12 VDC not available with this model.

80 SERIES

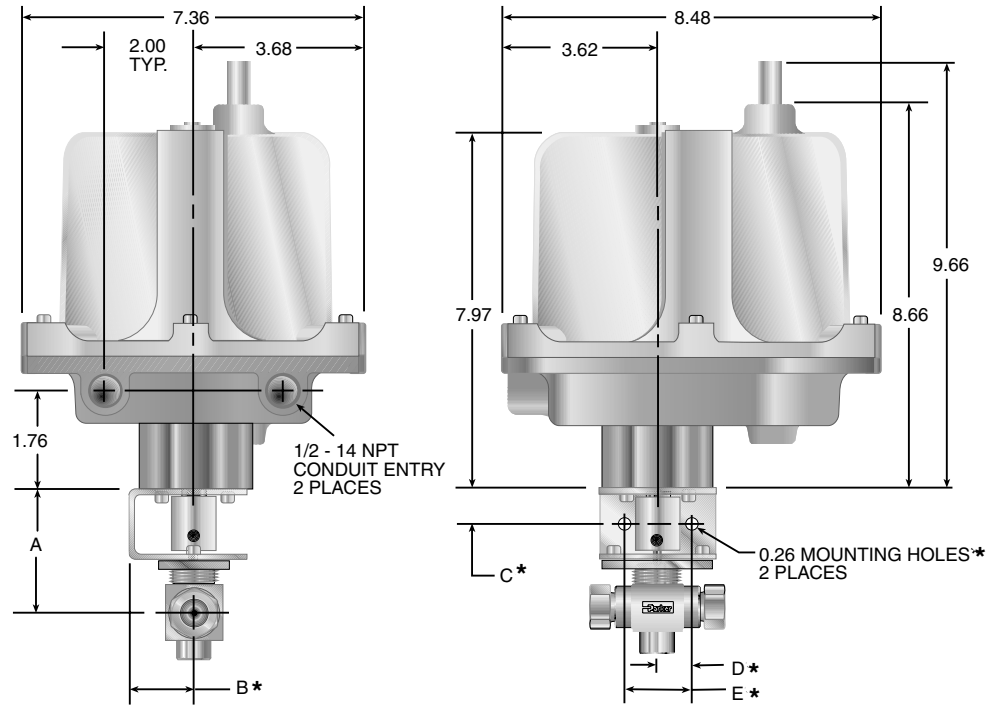

Dimensional Data

Valve Type	A		B*		C*		D*		E*	
	Inch	mm	Inch	mm	Inch	mm	Inch	mm	Inch	mm
B2	2.23	56.6								
B6	2.49	63.2								
B8	2.91	73.9								
MB2	2.33	59.2	1.61	40.9	0.80	20.3	0.75	19.1	1.50	38.1
MB4	2.33	59.2								
MB6	2.48	63.0								
HB4	2.70	68.6								
SB8	2.94	74.7								
SB12	3.03	77.0								
SB16	3.27	83.1	N/A	N/A	N/A	N/A	N/A	N/A	N/A	N/A
SB20	3.46	87.9								
SB24	3.73	94.7								
SB32	3.92	99.6								

*Not applicable with SB Series Ball Valves

Actuator Model	Breakaway Torque in lb (N m)	Standard Duty Cycle				DC			
		Cycle Time (sec)	Voltage	Duty Cycle	Amp** Draw (@115 VAC)	Cycle Time (sec)	Voltage	Duty Cycle	Amp** Draw (@12 VDC)
81	150 (17.0)	10	115	75%	0.3	5	12 VDC	100%	1.1
82	300 (34.0)	15	230		0.3	10	or		1.1
83	600 (67.8)	30	OR		0.3	15	24 VDC†		1.1
84‡	1000 (113.0)	25‡	24 VAC		0.5	15‡			2.6

NOTE: Cycle times reflect 90° rotation. For 180° rotation, double the cycle time.

**Amps rated at full running torque. Amp draws shown are for 115 VAC only. For 230 VAC, consult the factory.

†24 VDC cycle time and amp draw are half of 12 VDC.

‡Large 80 Series enclosure must be ordered (consult factory).

Electric Actuators

Actuator Selection Tables

Valve Series	Flow Pattern	Seat Material	Recommended Actuator					
			70 Series					80 Series
			115 VAC	230 VAC	24 VAC	12 VDC	24 VDC	All Voltages
B Series	2-Way	All	71	71	71	73	72	81
B Series	3-Way	All	71X	71X	71X	73X	72X	81X
MB Series	2-Way	All	71	71	71	73	72	81
MB Series	3-Way	All	71X	71X	71X	73X	72X	81X
HB Series	2-Way	All	71	71	71	73	72	81
HB Series	3-Way	All	71X	71X	71X	73X	72X	81X
SB8	2-Way	T	71	71	71	73	72	81
SB12	2-Way	T	71	71	71	73	72	81
SB16	2-Way	T	71	71	71	73	72	81
SB20	2-Way	T	71	71	71	73	72	81
SB24	2-Way	T	72	72	72	73	72	82
SB32	2-Way	T	72	72	72	73	72	82
SB8	2-Way	RT	71	71	71	73	72	81
SB12	2-Way	RT	71	71	71	73	72	81
SB16	2-Way	RT	71	71	71	73	72	81
SB20	2-Way	RT	72	72	72	73	72	82
SB24	2-Way	RT	73	73	73	73	73	83
SB32	2-Way	RT	73	73	73	73	73	83
SB8	2-Way	PF	71	71	71	73	72	81
SB12	2-Way	PF	71	71	71	73	72	81
SB16	2-Way	PF	71	71	71	73	72	81
SB20	2-Way	PF	72	72	72	73	72	82
SB24	2-Way	PF	72	72	72	73	72	82
SB32	2-Way	PF	73	73	73	73	73	83
SB8	2-Way	PKP	71	71	71	73	72	81
SB12	2-Way	PKP	72	72	72	73	72	82
SB16	2-Way	PKP	72	72	72	73	72	82
SB20	2-Way	PKP	73	73	73	73	73	83
SB24	2-Way	PKP	73	73	73	73	73	83
SB32	2-Way	PKP	-	-	-	-	-	84
SB8	2-Way	UPE	71	71	71	73	72	81
SB12	2-Way	UPE	71	71	71	73	72	81
SB16	2-Way	UPE	71	71	71	73	72	81
SB20	2-Way	UPE	72	72	72	73	72	82
SB24	2-Way	UPE	72	72	72	73	72	82
SB32	2-Way	UPE	72	72	72	73	72	82
SB8	2-Way	DE	71	71	71	73	72	81
SB12	2-Way	DE	71	71	71	73	72	81
SB16	2-Way	DE	71	71	71	73	72	81
SB20	2-Way	DE	73	73	73	73	73	83
SB24	2-Way	DE	73	73	73	73	73	83
SB32	2-Way	DE	-	-	-	-	-	84
SB8	3-Way	T	71X	71X	71X	73X	72X	81X
SB12	3-Way	T	71X	71X	71X	73X	72X	81X
SB16	3-Way	T	71X	71X	71X	73X	72X	81X
SB24	3-Way	T	72X	72X	72X	73X	72X	82X
SB32	3-Way	T	73X	73X	73X	73X	73X	83X
SB8	3-Way Diverter	T	71X	71X	71X	73X	72X	81X
SB12	3-Way Diverter	T	71X	71X	71X	73X	72X	81X
SB16	3-Way Diverter	T	71X	71X	71X	73X	72X	81X
SB24	3-Way Diverter	T	72X	72X	72X	73X	72X	82X
SB32	3-Way Diverter	T	72X	72X	72X	73X	72X	82X

How To Order Mounting Bracket Kits

Valve Series	Mounting Bracket Kit Part Numbers	
	70 Series	80 Series
B2L	MK-B2L-70	MK-B2L-80
B2X	MK-B2X-70	MK-B2X-80
B6L	MK-B6L-70	MK-B6L-80
B6X	MK-B6X-70	MK-B6X-80
B8L	MK-B8L-70	MK-B8L-80
B8X	MK-B8X-70	MK-B8X-80
MB2L	MK-MB4L-70	MK-MB4L-80
MB2A	MK-MB4L-70	MK-MB4L-80
MB2X	MK-MB4X-70	MK-MB4X-80
MB4L	MK-MB4L-70	MK-MB4L-80
MB4A	MK-MB4L-70	MK-MB4L-80
MB4X	MK-MB4X-70	MK-MB4X-80
MB6L	MK-MB6L-70	MK-MB6L-80
MB6A	MK-MB6L-70	MK-MB6L-80
MB6X	MK-MB6X-70	MK-MB6X-80
HB4L	MK-HB4-70	MK-HB4-80
HB4X	MK-HB4-70	MK-HB4-80
SB8L	MK-SB12-70	MK-SB12-80
SB8X	MK-SB12-70	MK-SB12-80
SB12L	MK-SB12-70	MK-SB12-80
SB12X	MK-SB12-70	MK-SB12-80
SB16L	MK-SB20-70	MK-SB20-80
SB16X	MK-SB20-70	MK-SB20-80
SB20L	MK-SB20-70	MK-SB20-80
SB24L	MK-SB32-70	MK-SB32-80
SB24X	MK-SB32-70	MK-SB32-80
SB32L	MK-SB32-70	MK-SB32-80
SB32X	MK-SB32-70	MK-SB32-80

NOTE: Mounting bracket kits include one mounting bracket, one nut plate, one coupling, six socket head cap screws, and two set screws.

If the bracket spacer block is required, order separately using the following nomenclature:
SPACER-ACT-75

NOTE: For the SB Series, actuators can be down sized to fit the application. The actuator selection tables utilize valve combinations at full operating pressures.

How To Order Kits For Field Assembly

Kit Description	70 Series Part Number	80 Series Part Number
Extra Limit Switch *	KIT-LSW-70	KIT-LSW-80
Heater & Thermostat (115 VAC) **	KIT-HTR-70-115AC	KIT-HTR-80-115AC
Heater & Thermostat (230 VAC) **	KIT-HTR-70-230AC	KIT-HTR-80-230AC
Heater & Thermostat (24 VAC) **	KIT-HTR-70-24AC	KIT-HTR-80-24AC
Positioner (4-20mA, 115 VAC)	Not Available	KIT-POSITIONER-420-115AC
Positioner (0-10 VDC, 115 VAC)	Not Available	KIT-POSITIONER-010-115AC

* For two additional limit switches on the 80 Series, order a quantity of two KIT-LSW-80.

** Heater and thermostat for DC voltages are factory installed only.

How to Order: Electric Actuators for Field Assembly

The correct part number is easily derived by following the circled number sequence.

Example: $\frac{71}{\textcircled{1}}$ $\frac{-}{\textcircled{2}}$ $\frac{-}{\textcircled{3}}$ $\frac{I}{\textcircled{4}}$

Describes a Model 71, 2-Way electric actuator unit with a NEMA 4 and 4X rating, a 115 VAC motor with optional heater and thermostat.

$\textcircled{1}$ Actuator Model	$\textcircled{2}$ Flow Pattern	$\textcircled{3}$ Voltage	$\textcircled{4}$ Options
71 72 73 71R 72R 73R 81 82 83 84	Blank - 2-Way X - 3-Way	Blank - 115 VAC A - 230 VAC B - 24 VAC C - 12 VDC D - 24 VDC	T - Heater and Thermostat S# - Additional Limit Switch; # = number of limit switches required [†] C - Modulating Control Package with position re-transmit (4-20mA, 0-10 VDC includes potentiometer) [‡] F - Position Indicator (70R Series only) CE - European Conformity Marking

NOTE: Mounting bracket kits are required when ordering actuators for field assembly.

Electric Actuators Factory Assembled

The correct part number is easily derived by following the circled number sequence.

Example: $\frac{4Z-MB6XPFA-SS}{\textcircled{1}}$ - $\frac{81}{\textcircled{2}}$ $\frac{X}{\textcircled{3}}$ $\frac{A}{\textcircled{4}}$ $\frac{-}{\textcircled{5}}$

Describes a Model 81, 3-Way electric actuator unit with a NEMA 4, 4X, 7 and 9 rating, a 230 VAC motor and no options, mounted on a MB Series ball valve.

$\textcircled{1}$ Valve Part Number	$\textcircled{2}$ Actuator Model	$\textcircled{3}$ Flow Pattern	$\textcircled{4}$ Voltage	$\textcircled{5}$ Options
See the "How to Order" section in the applicable catalog for the desired valve series	71 72 81 73 82 71R 83 72R 84 73R	Blank - 2-Way X - 3-Way	Blank - 115 VAC A - 230 VAC B - 24 VAC C - 12 VDC D - 24 VDC	T - Heater and Thermostat S# - Additional Limit Switch; # = number of limit switches required [†] C - Modulating Control Package with position re-transmit (4-20mA, 0-10 VDC includes potentiometer) [‡] F - Position Indicator (70R Series only) CE - European Conformity Marking

NOTE: Parker electrically actuated, B Series Ball Valves should be ordered with elastomeric stem packing and seals or the optional live-loaded PTFE packing. This reduces the need for any further packing adjustment after receipt from the factory.

[†]The 70 Series offers one additional limit switch and cam; the 70R and 80 Series offer up to two additional limit switches and cams.

[‡]For 80 Series electric actuators only.

WARNING

FAILURE, IMPROPER SELECTION OR IMPROPER USE OF THE PRODUCTS AND/OR SYSTEMS DESCRIBED HEREIN OR RELATED ITEMS CAN CAUSE DEATH, PERSONAL INJURY AND PROPERTY DAMAGE.

This document and other information from Parker Hannifin Corporation, its subsidiaries and authorized distributors provide product and/or system options for further investigation by users having technical expertise. It is important that you analyze all aspects of your application and review the information concerning the product or system in the current product catalog. Due to the variety of operating conditions and applications for these products or systems, the user, through its own analysis and testing, is solely responsible for making the final selection of the products and systems and assuring that all performance, safety and warning requirements of the application are met.

The products described herein, including without limitation, product features, specifications, designs, availability and pricing, are subject to change by Parker Hannifin Corporation and its subsidiaries at any time without notice.

Offer of Sale

The items described in this document are hereby offered for sale by Parker Hannifin Corporation, its subsidiaries or its authorized distributors. This offer and its acceptance are governed by the provisions stated in the "Offer of Sale" located in Catalog 4110-U Needle Valves (U Series).

© Copyright 2000, Parker Hannifin Corporation. All Rights Reserved.



Catalog 4123-EA, 20M, 01/01

Parker Hannifin Corporation
Instrumentation Valve Division
2651 Alabama Highway 21 North
Jacksonville, AL 36265-9681
USA
Phone: (256) 435-2130
Fax: (256) 435-7718
www.parker.com/IVD



Parker Hannifin plc
Instrumentation Products Division
Riverside Road
Pottington Business Park
Barnstaple, Devon EX31 1 NP
England
Phone: +44 (0) 1271 313131
Fax: +44 (0) 1271 373636
Email: ipd@parker.com
www.parker.com/IPD

